

PAMS Technical Documentation

NSD-3 Series Transceivers

System Module

CONTENTS

Transceiver NSD-3	5
Introduction	5
Modes of Operation	5
Interconnection Diagram	6
System Module	7
Circuit Description	7
Connectors	7
System Connector	7
RF-Connector	9
Baseband Module	10
Block Diagram	10
Baseband Elements	10
Baseband ASICS Description	10
MAD4	10
CAFÉ	10
CCONT	11
PENTA	11
CHAPS	11
Memories	12
Clocks	12
Baseband Power Distribution	13
Description	13
CCONT Regulators	14
Charging	14
Watchdog	14
Power Up	15
Charging – CHAPS	18
Power Down	21
RF to Baseband Interface	22
Audio control	23
Digital control	24
MAD4	24
MAD Interfaces	24
Signal Definitions	25
CAFE Submodule	31
Audio CODEC	33
EMC Strategy	34
RF Module	35
Transmitter	35
Antenna	35
Diplexer	35
1900 MHz Transmitter	35
1900MHz Duplexer Scorpion	35
1900 MHz Isolator	35

1900 MHz Power Amplifiers Snapper	36
1900 MHz Transmitter Interstage Filtering	36
1900 MHz Transmitter Up-converter Apache	36
800 MHz Transmitter	37
800 MHz SAW Duplexer	37
800 MHz Isolator	38
800 MHz Power Amplifiers Shark	38
800 MHz Transmitter Up-converter Odyssey	38
800 MHz and 1900 MHz Transmitter Intermediate Frequency (TIF)	39
1900 MHz Receiver	40
1900 MHz LNA and Interstage Filter	40
1900 MHz Down Converter IC STEALTH	40
800 MHz and 1900 MHz CDMA IF filter	41
800 MHz Receiver	41
800 MHz Down Converter IC VOYAGER	42
800 MHz AMPS IF Filter	42
Receiver Intermediate Frequency (RIF)	42
CDMA AGC	43
IQ Demodulator	43
AMPS Second Down conversion	43
AMPS Limiter	43
Synthesizers	43
UHF LOs 1 GHz and 2 GHz	44
Receiver VHF LO	44
Transmitter VHF LO	44
RF – Base Band Connections	45

Schematic Diagrams: UF4D (A3 size, at the back of the binder)

BB-RF interface (Version 20 Edit 3) for layout version 20	A-1
Circuit Diagram of Baseband (Version 20 Edit 3) layout version 20	A-2
Circuit Diagram of Power Supply (Version 20 Edit 9) layout 20	A-3
Circuit Diagram of RF Block (Version 20 Edit 3) layout version 20	A-4
Circuit Diagram of RX (Version 20a Edit 4) for layout version 20	A-5
Circuit Diagram of TX (Version 20a Edit 8) for layout version 20	A-6
Circuit Diagram of Synthesizer (Version 20a Edit 5) layout 20 .	A-7
Circuit Diagram of Cafe (Version 20a Edit 5) for layout version 20	A-8
Circuit Diagram of MAD4 (Version 20a Edit 4) for layout version 20	A-9
Circuit Diagram of MAD4 External Memories (V.20a Edit 4) layout 20	A-10
Layout Diagram of UF4 – Top (Version 20)	A-11
RF Troubleshooting Test Points for UF4D – Top (Version 20) .	A-12
RF Troubleshooting Test Points for UF4D – Bottom (Version 20)	A-12

This page intentionally left blank.

Transceiver NSD-3

Introduction

The NSD-3 is a tri-mode radio transceiver unit for the CDMA 800/1900MHz and AMPS network. The transceiver is true 3 V transceiver. The transceiver consists of System/RF module (UF4D), User interface module (UE4) and assembly parts.

The transceiver has full graphic display, and the user interface is based on two soft keys.

The transceiver has leakage tolerant earpiece.

The antenna is fixed. External antenna connection is provided by rear RF connector

Modes of Operation

There are five different operation modes:

- power off mode
- idle mode
- active mode
- charge mode
- local mode

In the power off mode only the circuits needed for power up are supplied.

In the idle mode circuits are powered down and only sleep clock is running.

In the active mode all the circuits are supplied with power although some parts might be in the idle state part of the time.

The charge mode is effective in parallel with all previous modes. The charge mode itself consists of two different state: charge and maintenance mode.

The local mode is used for alignment and testing.

Interconnection Diagram

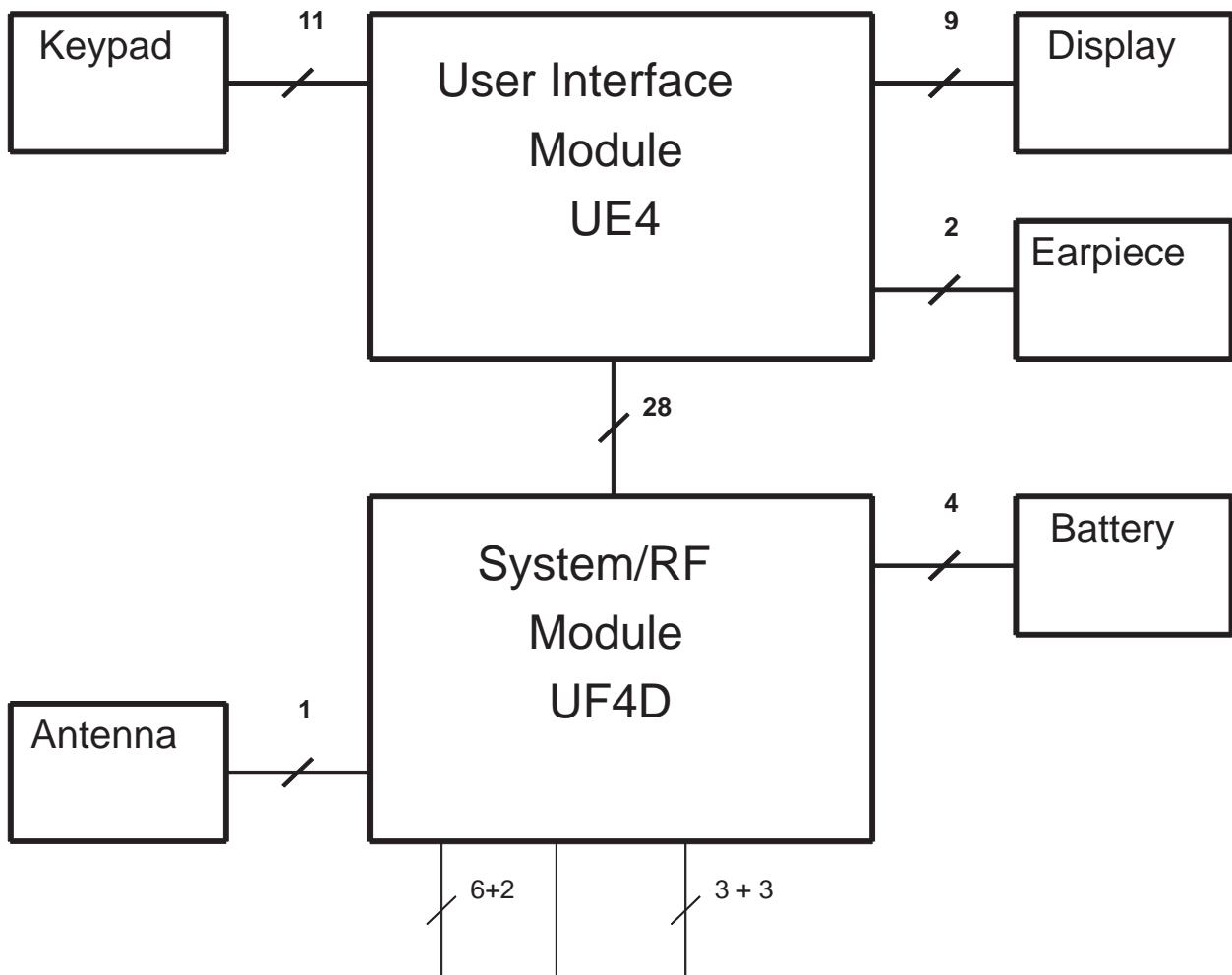

System Module

Circuit Description

The transceiver electronics consist of the Radio Module, RF + System blocks, the UI PCB, the display module and audio components. The keypad and the display module are connected to the Radio Module with a connectors. System blocks and RF blocks are interconnected with PCB wiring. The Transceiver is connected to accessories via a bottom system connector with charging and accessory control.

The RF block is designed for a handportable phone which operates in the CDMA 800 system. The purpose of the RF block is to receive and demodulate the radio frequency signal from the base station and to transmit a modulated RF signal to the base station.

Connectors

System Connector

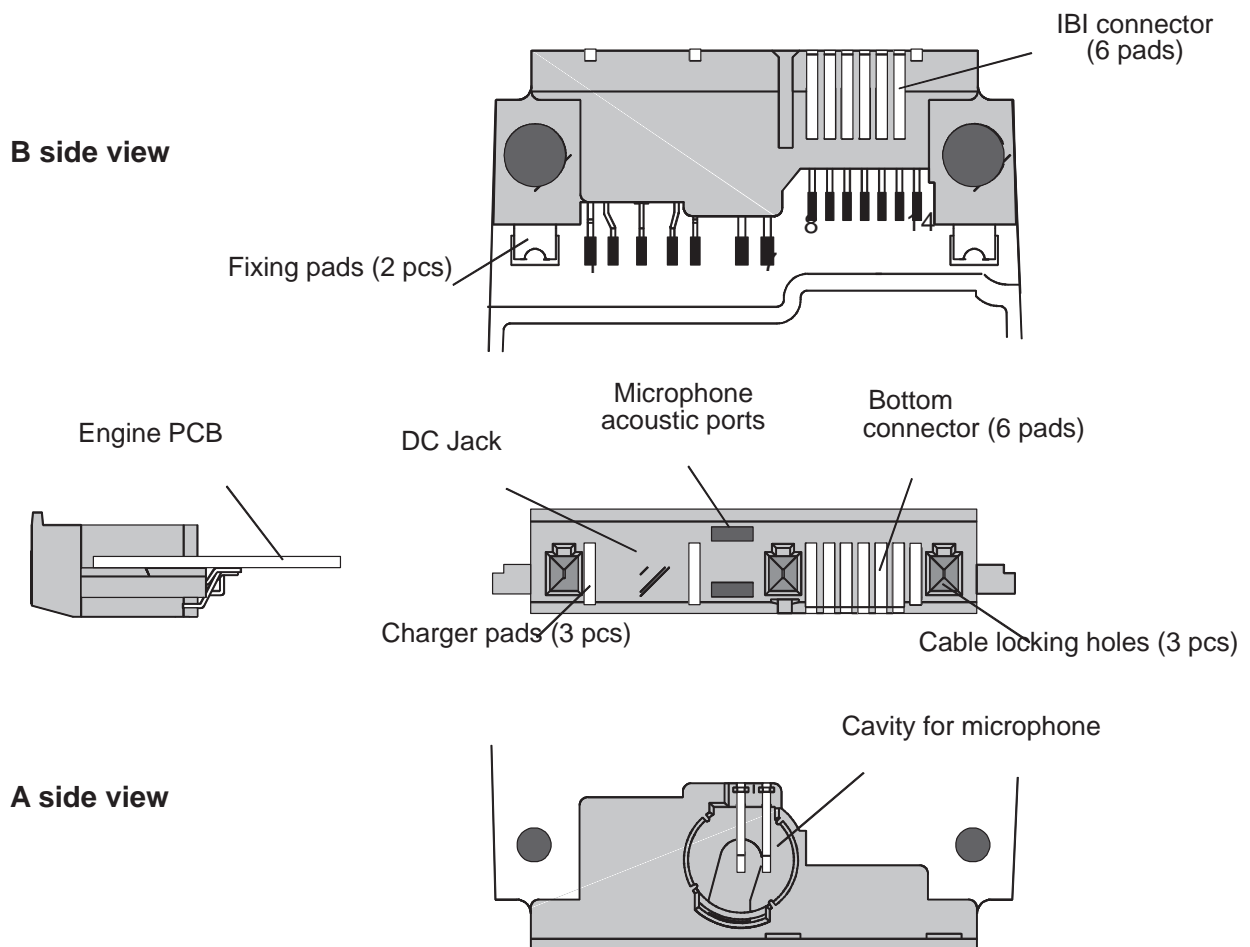

Note: Intelligent Battery Interface, IBI, is an accessory interface on the battery side of the phone including the same signals as the bottom connector. The accessory (e.g. an IBI accessory) can be a battery pack with

special features or an accessory module attached between the phone and a normal battery pack.

Pin	Name	Function	Description
1	V_IN	Bottom charger contacts	Charging voltage.
2	L_GND	DC Jack	Logic and charging ground.
3	V_IN	DC Jack	Charging voltage.
4	CHRG_CTRL	DC Jack	Charger control.
5	CHRG_CTRL	Bottom charger contacts	Charger control.
6	MICP	Microphone	Microphone signal, positive node.
7	MICN	Microphone	Microphone signal, negative node.
8	XMIC	Bottom & IBI connectors	Analog audio input.
9	SGND	Bottom & IBI connectors	Audio signal ground.
10	XEAR	Bottom & IBI connectors	Analog audio output.
11	MBUS	Bottom & IBI connectors	Bidirectional serial bus.
12	FBUS_RX	Bottom & IBI connectors	Serial data in.
13	FBUS_TX	Bottom & IBI connectors	Serial data out.
14	L_GND	Bottom charger contacts	Logic and charging ground.

RF-Connector

The RF-connector is needed to utilize the external antenna with Car Cradle. The RF-connector is located on the back side of the transceiver on the top section. The connector is plug type connector with special mechanical switching.

Accessory side of connector Phone side of connector
Part will be floating in
car holder

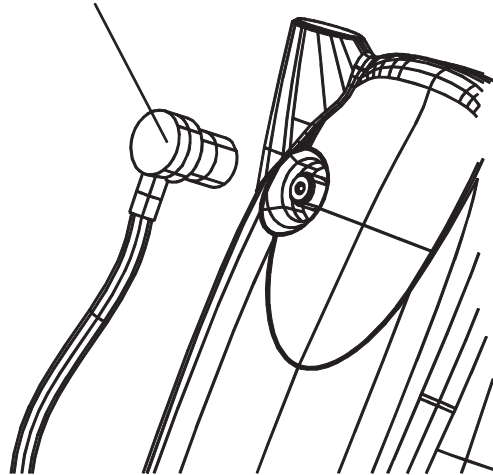

Baseband Module

Block Diagram

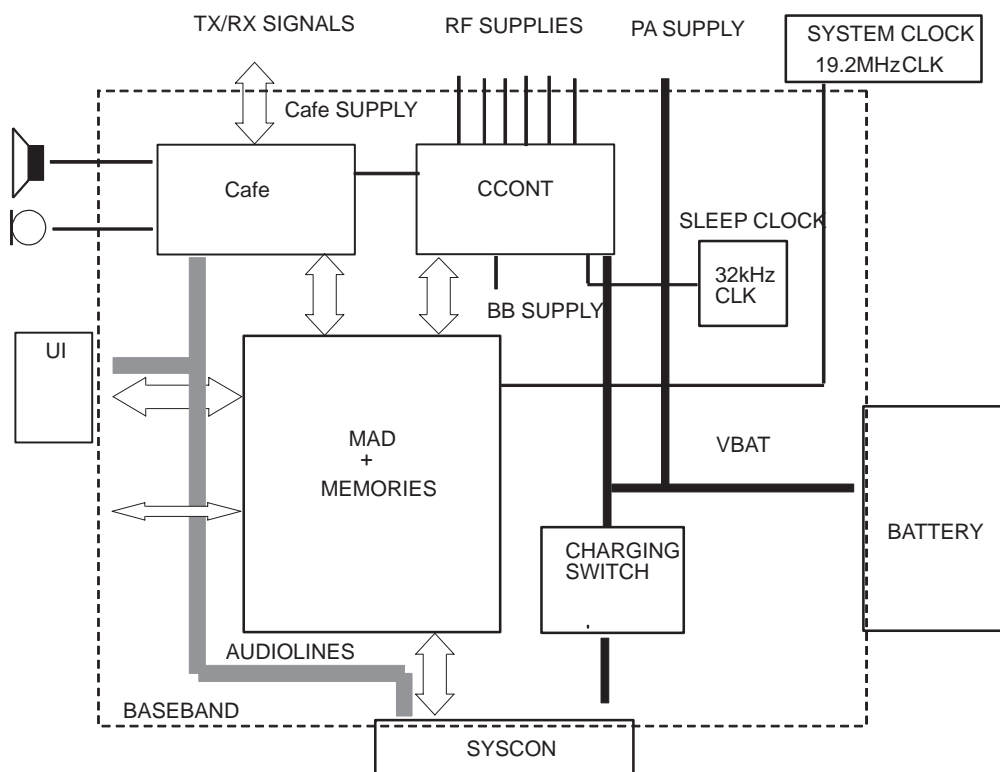

Baseband Elements

Baseband refers to all technology elements in the phone design, which do not include RF functions. The Baseband Module therefore includes audio, logic control, signal processing, power supply, and user interface functions. Baseband functionality of this product consists of third generation Digital Core Technology (DCT3) design solutions.

Baseband ASICS Description

MAD4

The MAD4 ASIC contains four main components: DSP, MCU, RAM, and ROM. This ASIC controls logic functions for the user interface, USART and PWMs, CAFÉ, Control Timing and Interrupts (CTI), RX Modem, RF Interface, Accessory Interface, and CDMA functionality.

The DSP controls the RF power and implements the compressor and expander for AMPS, the vocoders for CDMA and DTMF tone generation.

The MCU performs tasks such as UI control, timers, PUP control, RX Modem interface, audio control, evaluation of sensor data from CCONT A/D, and battery charging control.

CAFÉ

The CAFÉ ASIC provides CODEC functionality (A/D and D/A conversions for voice data, microphone and speaker amplification, variable RX and TX

Audio Gain), provides system clock squaring, utilizes PLL for CDMA clock generation from system clock, and interfaces to the RF section and to MAD4.

CCONT

The CCONT ASIC provides linear regulated power to most of the phone. It has a multiplexed A/D converter for temperature sensor digitization, battery voltage, charger voltage, current consumption, and battery type detection. An external 32 kHz oscillator circuit is connected to CCONT, which is used for sleep clock generation. It also has a watchdog circuit used to power off the phone in the event that MCU receives an interrupt from power key depression, or an event has caused a process to over run and MCU does not service the register to prevent the watchdog timer from timing out.

PENTA

The PENTA IC chip operates as a low noise, low drop out regulator with 5 independent 2.8-volt outputs used to power on various sections of the RF module. The PENTA IC has 5 control inputs are controlled by the MAD4 ASIC.

CHAPS

CHAPS operates as an integrated power switch for controlling charger current. Its features are limited start up current, limited maximum switch current, transient voltage protection, voltage limit protection, and reverse voltage protection. It is designed to be used with either a single lithium cell or three nickel cells battery types.

Memories

SRAM

External SRAM is used by MAD4. Size is 2 Mbit (256k x 8 bit).

FLASH MEMORY

Flash memory contains the main program code for the MCU and default EEPROM values. Size is 16 Mbit (1M x 16 bit), with layout compatability for an optional 8 Mbit chip (512k x 16 bit).

EEPROM

An EEPROM is used to store user data and tuning parameters. Size is 256 kbit (32k x 8), with optional 64k x 8 bit. A 2-wire serial interface is used for communication.

Clocks

System Clock and CDMA Clock

A 19.2 MHz signal is passed to the CAFÉ ASIC from the RF section. The CAFÉ then generates the 19.2 MHz system clock and the 9.8304 MHz CDMA clock, which are derived from the RF signal. Both of these clocks are passed to MAD4.

8kHz Frame Sync Clock

An 8 kHz frame sync is generated in MAD4 and passed to the CAFÉ in order to synchronize the internal CAFÉ clocks with the equivalent MAD4 clocks. This signal is also used to “frame” the CODEC voice data at 8kHz. The pulse width of the frame sync will be equal to one period of the 320 kHz clock, which is internal to CAFÉ.

Sleep Clock

Sleep clock is provided by CCONT and produces a 32.768 kHz clock used by MAD4 when it is in sleep mode. The crystal oscillator in the external CCONT circuitry to CCONT is not automatically started when the battery is connected, but after power up the oscillator is always running, even during power off periods. The only exception is when the battery is removed.

UIF and CCONT Serial Clock (UIF_CCONT_SCLK)

This 960 KHz clock is used to synchronize serial data transmission on the UIF and CCONT serial data bus UIF_CCONT_SDIO.

Baseband Power Distribution

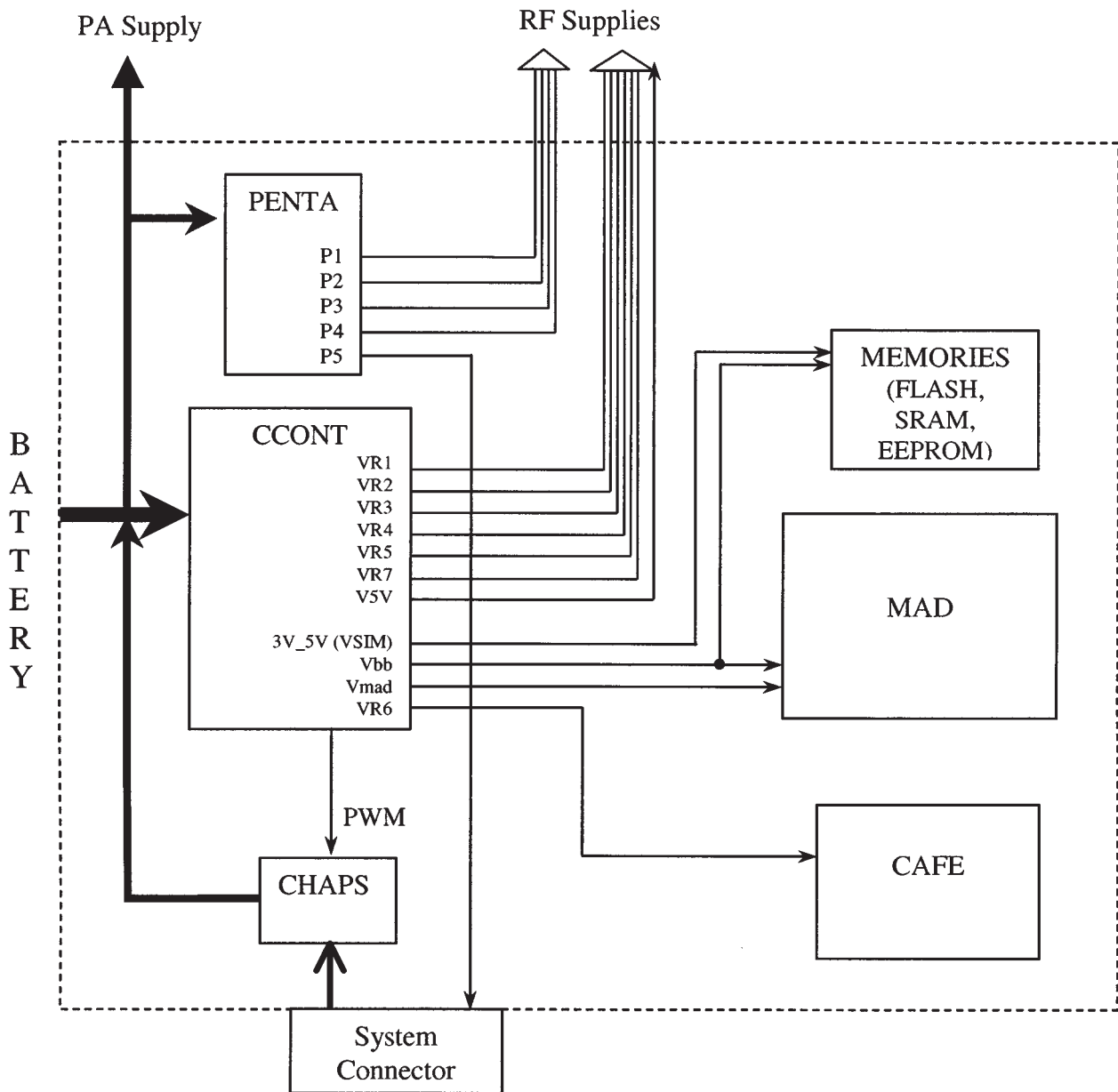

Description

Power management and distribution in the phone is handled by the CCONT asic. CCONT is a multi function power management IC which has seven 2.8V linear regulators for the RF-section of the phone. One 2.8V regulator is used to power up the baseband of the phone, and its output is called Vbb. Additionally, one adjustable regulator is used to power up certain parts of the baseband. There are also a 5V charge pump, 5V regulator and 3/5V regulator.

The main functions are voltage regulation, power up/down procedures, reset logic, charging control (PWM) , watchdog, sleep control, ADC and real time clock.

CCONT Regulators

Battery voltage VBAT is connected to CCONT which regulates all the supply voltages VBB, VR1–VR7, V2V, VR1_SW, VSIM and V5V. CCONT's default startup mode is to turn on VR1, VBB, V2V, VR6 and Vref in power-up. Vrefs default value is 1.5V, but in this phone we use 1.25V for Vref, so one of the first things MAD4 does on power up is to do a write to CCONT to change Vref to 1.25V.

VBB is used as baseband power supply for all digital parts, and it is on whenever the phone is powered up. V2V is reserved for a later version of the MAD4 ASIC which will have a lower core voltage. When the low voltage core version of MAD4 is available, V2V will be connected to those pins on MAD4 which power the core. VSIM is used as programming voltage for the Flash memory after the phone is cut out of the panel. This is necessary if re-flashing is needed after initial flash programming in production. V5V is used for RF parts only. VR6 supplies the power for CAFE.

VR1 is used for the VCTCXO supply. VR1_SW is derived from VR1 inside CCONT, and is actually the same voltage, but can be separately switched on and off. This VR1_SW is used as an optional external microphone bias voltage. CLK_EN signal to CCONT controls both the VR1 and VR6 regulators; they can be switched off in sleep modes, during standby.

CCONT regulators are controlled through a serial data bus from MAD4. Regulators VR3, 4, 5 and 7 are controllable through external pins; these pins forming a logical 'OR' function with the serial commands. If a regulator's control pin is at logic '1', that regulator will turn on. If the pins are not used for external control they are grounded.

Most of the regulator outputs depend on pin control. In the table the 'State in reset' is based on assumption that pin controls are '0'.

Charging

Charging can be performed in any operating mode. The charging algorithm is dependent on the battery technology used. A resistor internal to the battery pack indicates the battery type. The resistor value corresponds to a specific battery capacity. This capacity value is related to the battery technology as different capacity values are achieved by using different battery technologies.

The CCONTs A/D converter input measures the battery voltage, temperature, size and current.

NOTE: Power management circuitry controls the charging current delivered from the charger to the battery. Charging is controlled with a PWM input signal from CCONT. The pulse width is controlled by MAD4 and is sent to CCONT through a serial bus. The battery voltage rise is limited by turning CHAPS switch off when the battery voltage has reached the desired limits.

Watchdog

MAD4 must reset the CCONT watchdog regularly. CCONT watchdog time can be set through SIO between 0 and 63 seconds at 1 second steps. Af-

ter power-up the default value is 32 seconds. If the watchdog expires, CCONT will cut off all supply voltages. After total cut-off the phone can be re-started through any normal power-up procedure. CCONTs watchdog functionality may be temporarily disabled by holding CCONTs PWRONX/WDDISX pin at logic low.

Power Up

There are four ways to power on the phone.

1. Pressing the power button
2. Connecting a charger
3. An IBI interrupt on BTEMP
4. Internal RTC times out.

Each of four methods is described in general in the following sections.

When the battery is connected to phone, nothing will happen until the power-up procedure is initiated, for instance by pressing the power-button or by connecting a charger. After that the 32kHz crystal oscillator of CCONT is started (can take up to 1 sec), and the default regulators are powered up.

If a power down is done and the battery remains connected, the 32 kHz crystal oscillator keeps running in the CCONT.

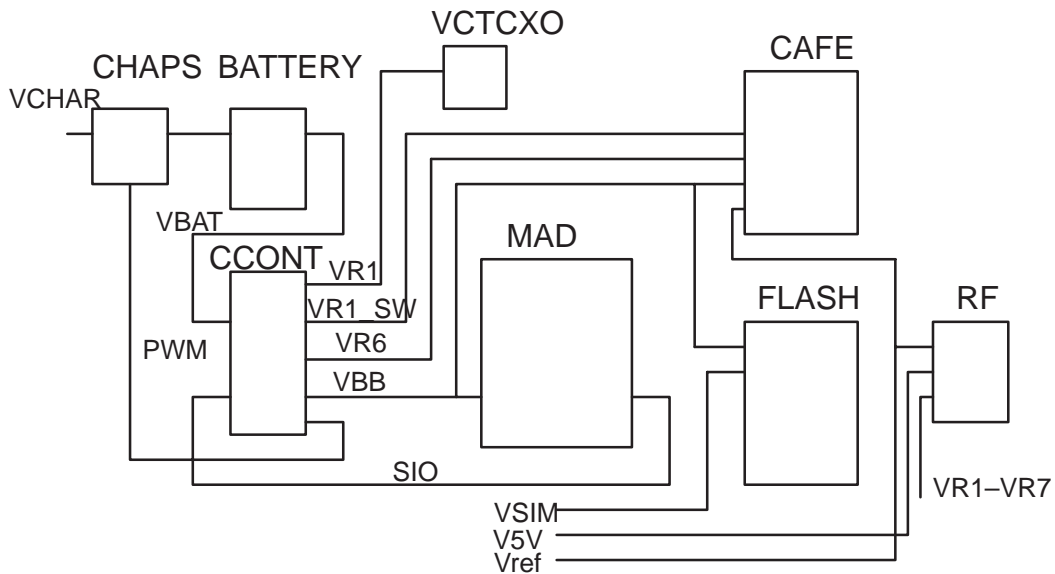

Power distribution diagram

Pressing power key

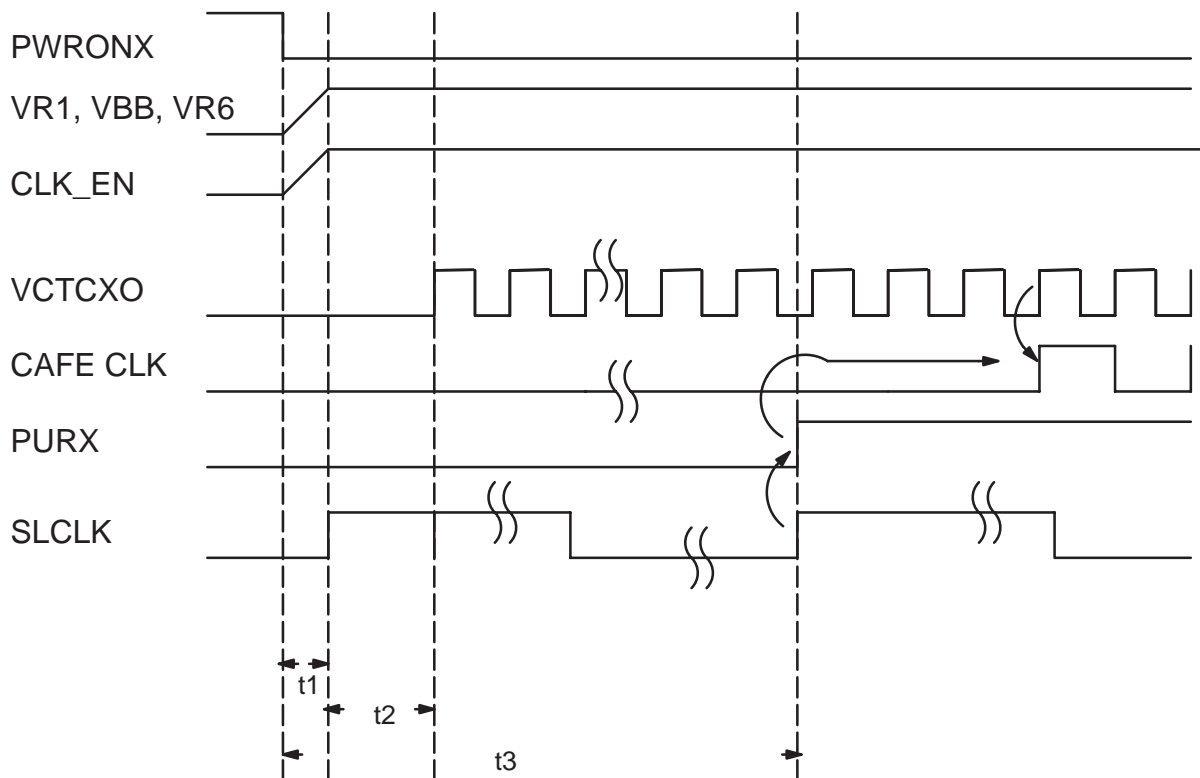

t1	< 1 ms
t2	1 – 6 ms, VCXO settled
t3	62 ms, PURX delay generated by CCONT

After PWR-key has been pushed, CCONT gives PURX reset to MAD4 and turns on VR1, VBB and VR6 regulators (if battery voltage has exceeded 3.0 V). VR1 supplies VCTCXO, VBB supplies MAD, and VR6 supplies digital parts of CAFE. After the initial delay, t2, VCTCXO starts to give a proper 19.2MHz clock to CAFE, which further divides it to 9.83MHz for MAD4. CAFE will output the 9.83MHz clock only after the PURX reset has been removed. After delay, t3, CCONT releases PURX and MAD4 can take control of the operation of the phone.

After MAD4s reset is released MCU-SW detects that the PWR-key is still pushed and shows the user that the phone is powering up by turning on the LCD and the lights. MCU-SW then powers up the RF receiver part.

V5V-regulator (for RF) default value is off in power-up, and can be controlled on via serial bus when needed.

Power up when charger connected

Normal battery voltage

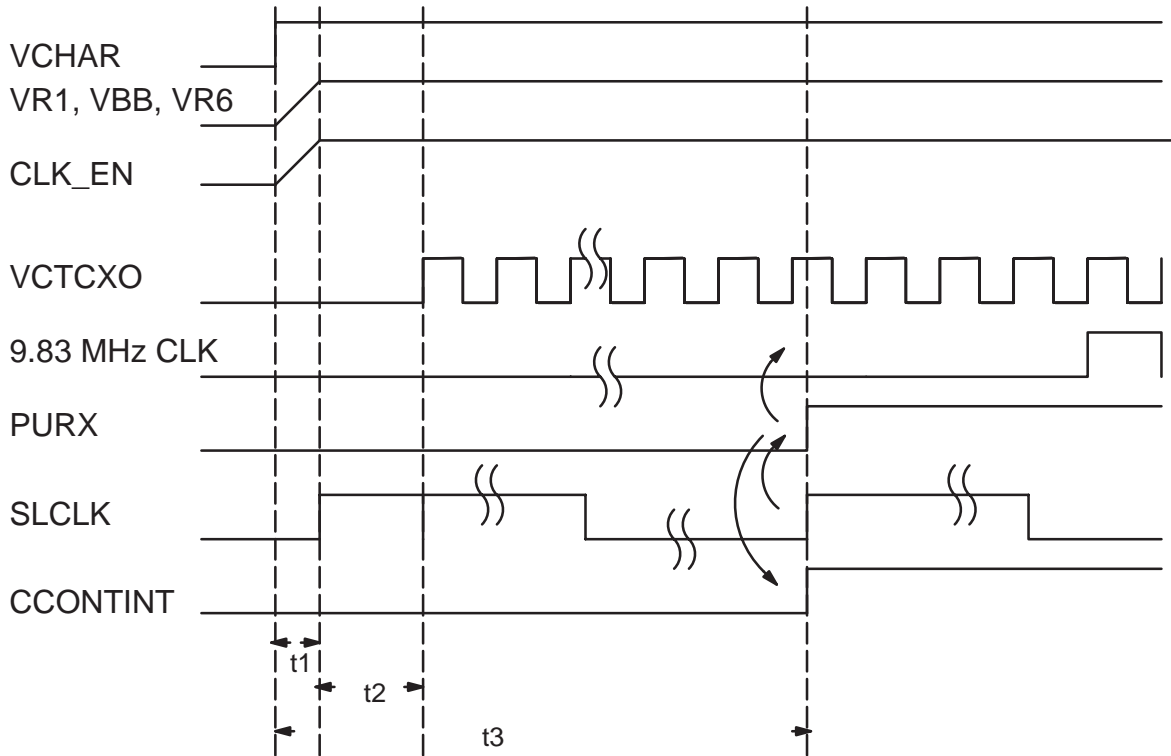

Power up, charger connected, VBAT > 3.0 V

The power up procedure is similar to the process described in the previous chapter with the exception that the rising edge of VCHAR triggers the power up in CCONT.

CCONT sets output CCONT_INT, MAD4 detects the interrupt and reads CCONT status register to find the reason for the interrupt (charger in this case). After reading the A/D register to determine that the charger voltage is correct MAD should initiate charging activities. The phone will remain in the so called "acting dead" state which means that only the battery bars are displayed on the LCD. The user perceives that the phone is off. If the power on button is pushed the LCD display will come on and startup will be the same as normal power on.

CCONT_INT is generated both when the charger is connected, and when the charger is disconnected.

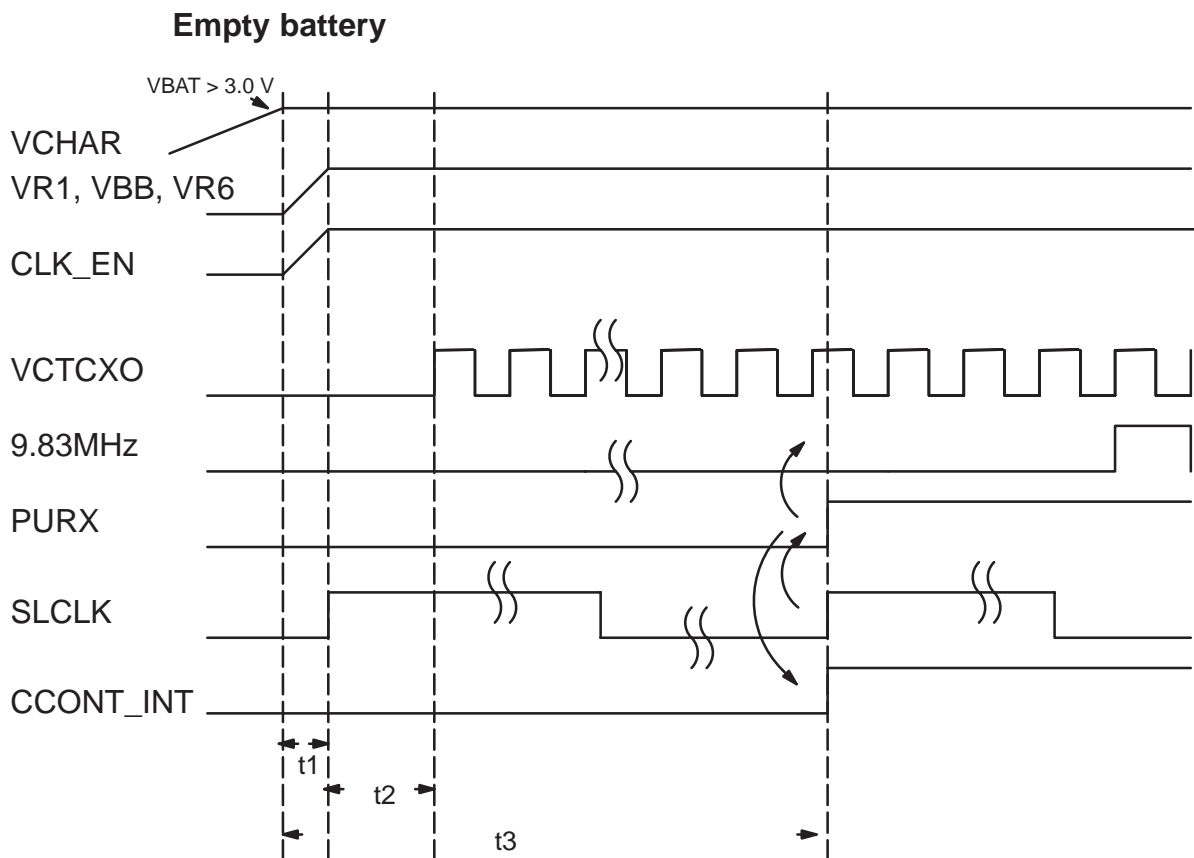

Power up, charger connected, VBAT < 3.0 V

Before battery voltage rises over 3.0 V CHAPS gives an initial charge (with limited current) to the battery. After battery voltage reaches 3.0V the power up procedure is as described in the previous section.

If a power down is done and the battery remains connected, the 32 kHz crystal oscillator keeps running in the CCONT. When a power-up is initiated again, the complete power-up sequence is described in the figure below. This time the power-up sequence is faster because the oscillator is already running.

Charging – CHAPS

CHAPS comprises the hardware for charging the battery and protecting the phone from over-voltage in charger connector.

The main functions are:

- transient, over-voltage and reverse charger voltage protection
- limited start-up charge current for a totally empty battery
- voltage limit when battery removed
- with SW protection protection against too high charging current

CHAPS is basically a PWM (Pulse Width Modulation) controlled switch which connects the charger to VBAT. MAD4 controls CHAPS by writing PWM values to CCONTs PWM register over a serial bus. CCONT then

outputs a PWM which is used by CHAPS to control the switch. In the case of an external fast charger, the PWM is available at the system connector to control the charger. In the case of a dead battery, shorted battery, or if the battery is below 3.0V, CHAPS supplies a controlled leakage current of about 180mA through the switch to attempt to bring the battery voltage up.

Pin number	Name	Description
1, 16	VCH	Charger voltage input
5	RSENSE	High current output, connected to current sense resistor of phone
12	VBAT	Battery voltage (connected to voltage sense part of CHAPS)
10	VBACK	Backup battery charging voltage output
9	LIM	Output voltage limit select input
7	PWM	Charging switch control input
8	CTIM	External capacitor for soft switching
2, 3, 4, 6, 11, 13, 14, 15	GND	Ground

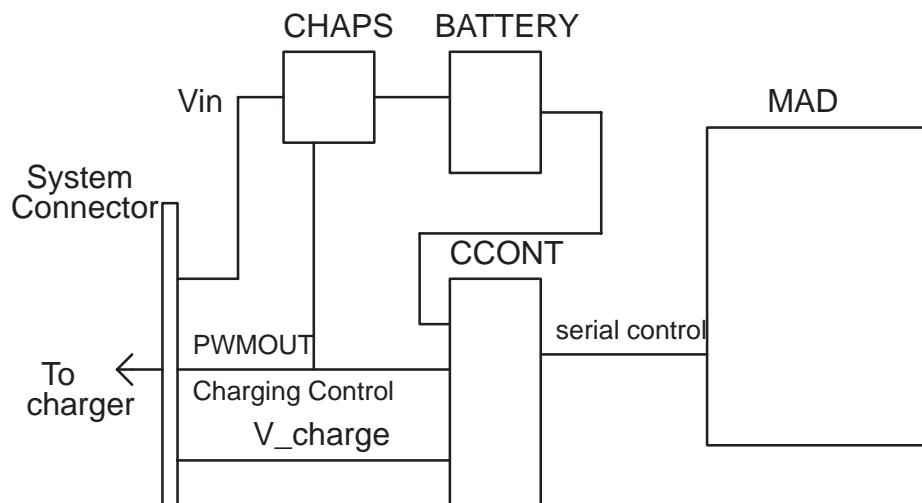

2-wire charging

With 2-wire charging the charger provides constant output current, and the charging is controlled by PWMOUT signal from CCONT to CHAPS. PWMOUT signal frequency is selected to be 1 Hz, and the charging switch in CHAPS is pulsed on and off at this frequency. The final charging current to the battery is controlled by adjusting the PWMOUT signal pulse width.

Both the PWMOUT frequency selection and pulse width control are made by the MCU which writes these values to CCONT.

The 2-wire charger is part number ACP-7, has full-wave rectified output, defined output voltage and impedance. Typical output current into empty battery is about 350 mA at nominal mains voltage.

3-wire charging

With 3-wire charging the charger provides adjustable output current, and the charging is controlled by PWMOUT signal from CCONT to Charger, with the bottom connector signal. PWMOUT signal frequency is selected to be 32 Hz, and the charger output voltage is controlled by adjusting the PWMOUT signal pulse width. The charger switch in CHAPS is constantly on in this case.

The 3-wire charger is part number ACP-9, a switchmode power supply (SMPS) adapter using 3-wire charging structure (controlled constant voltage). Typical output into an empty battery is about 850mA at nominal mains voltage.

Battery disconnected when charger is connected

From hardware point of view the phone could otherwise continue functioning normally, but if the charger voltage is higher than the maximum allowed battery voltage, this can damage the RF parts. Therefore, output overvoltage protection is needed in case the battery is removed when a charger is connected, or if a charger is connected before the battery to the phone. With a charger connected, if VBAT exceeds preset limits in CHAPS, the switch turns OFF immediately (soft switching bypassed). There are two voltage limits, VLIM1 and VLIM2. VLIM input = '0' selects VLIM1, VLIM input = '1' selects VLIM2.

Parameter	Symbol	Min	Typ	Max	Unit
Output voltage cutoff limit (during transmission or Li-battery)	VLIM1	4.4	4.6	4.8	V
Output voltage cutoff limit (no transmission or Ni-battery)	VLIM2	4.8	5.0	5.2	V

When the switch turns off due to an overvoltage condition, it stays off until the input voltage falls below the specified limit ($V_{CH} < V_{BAT}$). Phone software will stop the charging as fast as it detects that there is no battery present.

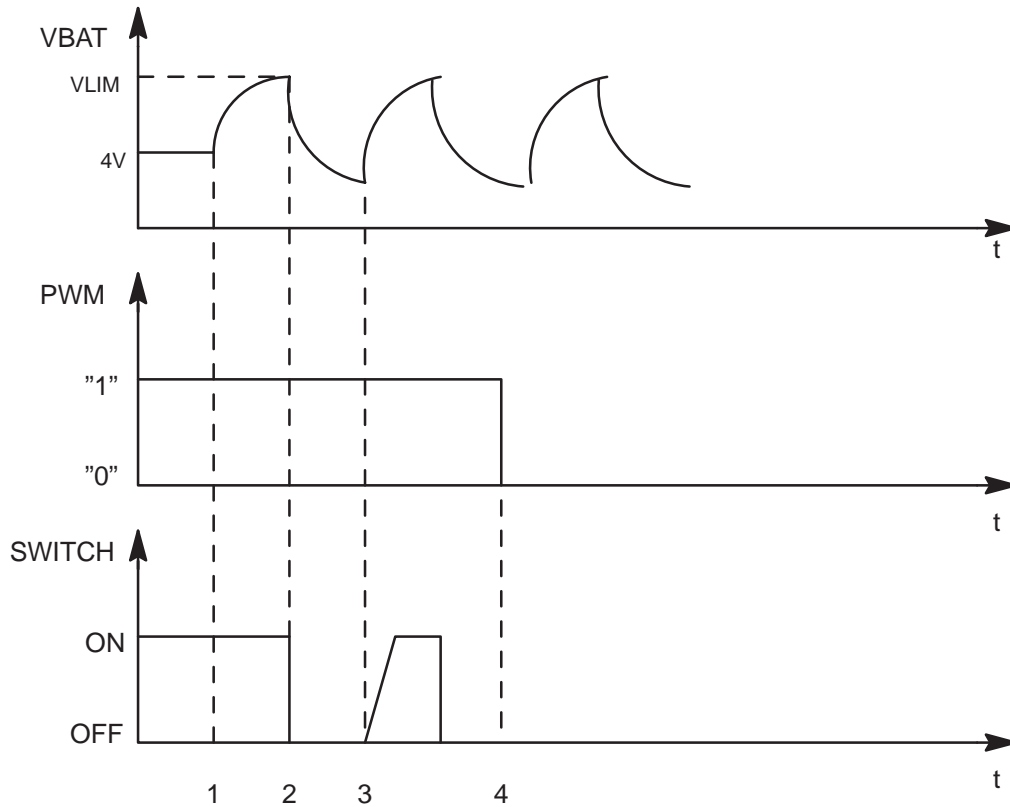

1. Battery removed, (standard) charger connected, VBAT rises (follows charger voltage)
2. VBAT exceeds limit VLIM(X), switch is turned immediately OFF
3. VBAT falls (because no battery) , also $V_{CH} < V_{BAT}$ (standard chargers full-rectified output). When $V_{CH} > V_{BAT}$ and $V_{BAT} < VLIM(X)$ → switch turned on again (also PWM is still HIGH) and VBAT exceeds VLIM(X).
4. Software sets PWM = LOW → CHAPS does not enter PWM mode

Output overvoltage protection when battery removed (in principle)

Power Down

Pressing power key

When the user wishes to turn the phone off and presses the power key, MAD (MCU SW) detects that PWR-key is pressed for a long enough time. After that the lights and LCD are turned off. MCU stops all the activities it was doing (e.g. ends a call), sends power off command to CCONT by writing a 'zero' amount of time to the watchdog register, and goes to idle-task. After the delay CCONT cuts all the supply voltages from the phone. Only the 32 kHz sleep clock remains running.

Note that the phone doesn't go to power off (from HW point of view) when the charger is connected and PWR-key is pushed. The user perceives that the phone is off, but in fact the phone is just acting as if it is off (this state is usually called "acting dead").

Battery charge low

As a battery discharges, energy management software keeps a constant watch on the voltage and displays an appropriate amount of battery bars.

When the battery discharges to a critical level the software notifies the user by beeping. If left on, the software will power off the phone at a VBAT of *TBD* V.

If the SW fails to power down the phone, hardware will take over and CCONT will do a reset and power down the phone when the battery voltage drops below 2.8 V.

Watchdog expires

If the SW fails to update the watchdog, the watchdog will eventually expire and CCONT cuts all the supply voltages to the phone. On startup, the initial value set in CCONT's watchdog timer register is 32.5 seconds. The watchdog is programmable from 0 to 63 seconds.

Disconnected battery

When battery is disconnected, immediate and totally uncontrolled power-down happens. Therefore a power off procedure in this case can not be described. One possible risk is that if the MCU is writing something to the EEPROM exactly at the same moment, the memory contents may be corrupted.

RF to Baseband Interface

The RF to Baseband interface consists of MAD4 and CAFÉ communicating with various parts of the RF module. The MAD4 ASIC produces the Pulse Duration Modulators (PDMs) which allow analog voltages to be used for RF control. It also controls the VCTCXO enable, as well as band and mode selects. MAD also controls the RF supply voltages through CCONT. The CAFÉ ASIC performs the A/D and D/A conversions for CDMA and AMPS RX and TX paths. CAFÉ also receives the VCTCXO 19.2 MHz signal and provides MAD4 with the 19.2 MHz system clock.

Audio control

Audio Controls and Processing

The audio control is handled by the MAD4 MCU. Speech coding functions are performed in MAD4 DSP. In transmission mode, the speech code is then sent to the CAFÉ ASIC for D/A conversion. In receiver mode, PCM coded blocks are read from the CAFE ASIC Both audio and RF CODECs reside in CAFÉ.

Earpiece

The internal earpiece is connected to the UI board by means of mounting springs for automated assembly. The 32-ohm impedance, dynamic type earpiece is connected to the differential output of the CAFÉ ASIC.

Microphone

The internal microphone is connected to the bottom connector by means of mounting springs. The microphone bias is provided by the CAFÉ ASIC.

Audio Accessory Interface

External audio is interfaced to the phone through the system connector. XEAR, XMIC, and SGND are the phone's external audio signal pins used for communication during a hands free accessory call.

Digital control

MAD4

The baseband functions are controlled by the MAD asic, which consists of a MCU, a system ASIC and a DSP. The CDMA specific asic is named as MAD4.

MCU

For general purpose processing applications.

DSP

The DSP is in charge of the channel and speech coding. The Main interfaces are to the MCU, and via System Logic to CAFE and RF.

System Logic

Peripheral interface:

- MCU Parallel I/O, UART, and PWM control (PUP)

Serial Accessory Interface (FBUS):

- Autobauding support (Acclf)
- Interface to external memories
- Address lines and chip select decoding (BUSC)
- RF Interface and Control (RFIfCtrl)
- Clocking, timing and interrupts (CTI)
- Sleep Control (SleepBlk)
- CAFE Control (CAFECtrl)

User Interface Control (UserIf)

Reset Generator (RstGen)

Clock Generator (ClkGen)

Test Interface (TestIf)

MAD Interfaces

UI and CCONT Serial interface

MAD4s serial interface is used to control the Serial LCD on the User Interface board, and to provide access to CCONTs registers. The DataSelX and DataClk are generated by MAD4 during both transmit and receive cycles. Each device has its own chip select signal and must hold its data pin in a high impedance state if its chip select is not active. Data must be valid on the rising edge of DataClk during both transmit and receive.

CAFE Interface

The MAD4 ASIC supplies an interface to the CAFE ASIC. This interface consists of parallel transmit and receive busses for CDMA and AMPS data, and a serial interface for Codec control and data.

FBUS

FBUS (Fast Bus) is a fast serial interface between the DSP and data accessories or the DSP and multipath analyzer. This interface is a full-duplex, asynchronous, two-line bus.

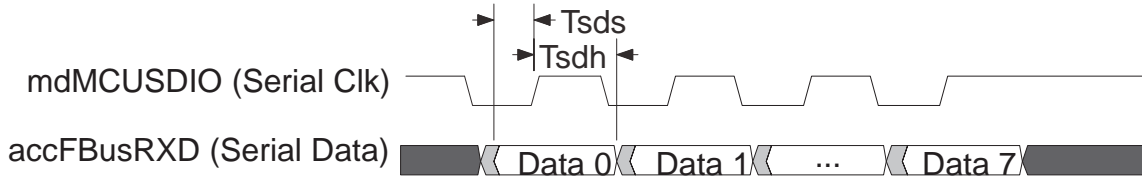

USART Synchronous Mode Receive (Flashing Mode)

MBUS

MBUS is the MCUs serial interface which is used for FLASH downloading (not program code), testing, and communication with external devices. Supported baud rates are 9.6, 19.2, 38.4 and 57.6 kbit/s.

JTAG Interface

The JTAG interface is used for MAD4 ASIC emulation. This interface provides for coemulation of the DSP and MCU.

TRUST Interface

TRUST (Trace Utility for Software Testing) is a hardware module used to capture tracing data from a phone during testing. It serves as a buffer memory, storing data from the address and data buses of the phone MCU until read by a PC. A time label is attached to each data word. The unit also includes a buffer for commands from the PC to the phone.

Signal Definitions

SIGNAL NAME	DESCRIPTION	From/To	Signal Characteristics	Notes
Busses, Strobes, and Clocks	Includes parallel and serial busses as well as data clocks, and chip selects			
ADD(20:0)	21-Bit Memory Address Bus	MAD4 to FLASH and SRAM	0 to 2.8V Digital	
DATA(15:0)	16-Bit Memory Data Bus	MAD4 to FLASH and SRAM	0 to 2.8V Digital	
RXD(11:0)	Receive Data	CAFE to MAD4	0 to 2.8V Digital	
TXD(7:0)	Transmit Data	MAD4 to CAFE	0 to 2.8V Digital	
EEPROMSCLK	SCLK to serial EEPROM	MAD4 to EEPROM	0 to 2.8V Digital	
EEPROMSDA	Serial data line for serial EEPROM.	MAD4 to EEPROM	0 to 2.8V Digital (Pullup)	
UIF_CCCONT_SCLK	Clock for UI and CCONT serial interface	MAD4 to CCONT and UI connector	0 to 2.8V Digital	
UIF_CCCONT_SDIO	User Interface and CCONT Serial Data	MAD4 to CCONT and UI connector	0 to 2.8V Digital	

SIGNAL NAME	DESCRIPTION	From/To	Signal Characteristics	Notes
CCONTCSX	CCONT Chip Select	MAD4 to CCONT	0 to 2.8V Digital	
LDCDS	LCD Chip Select	MAD4 to UI connector	0 to 2.8V Digital	
MEM(3)	Memory Read Strobe	MAD4 to FLASH and SRAM	0 to 2.8V Digital	
MEM(2)	Memory Write Strobe	MAD4 to FLASH and SRAM	0 to 2.8V Digital	
MEM(1)	RAM Chip Select	MAD4 to SRAM	0 to 2.8V Digital	
MEM(0)	FLASH chip enable	MAD4 to FLASH	0 to 2.8V Digital	
MBUS	MCU serial bus for external communication	MAD4 to System connector	0 to 2.8V Digital	
FBUS_TX	DSP Accessory UART Data Output	MAD4 to System connector	0 to 2.8V Digital	
FBUS_RX	DSP Accessory UART Data Input	System connector to MAD4	0 to 2.8V Digital	
ADATA	AMPS Data Input to RxModem (MAD4)	CAFE to MAD4	0 to 2.8V Digital	
CAFESIO(2)	CAFE I/F Frame Sync	MAD4 to CAFE	0 to 2.8V Digital	
CAFESIO(1)	CAFE I/F Serial Data from CAFE	CAFE to MAD4	0 to 2.8V Digital	
CAFESIO(0)	CAFE I/F Serial Data to CAFE	MAD4 to CAFE	0 to 2.8V Digital	
CLK9M20	19.2MHz System Clock	CAFE to MAD4	0 to 2.8V Digital	
CLK9M83	9.8304MHz CDMA Clock	CAFE to MAD4	0 to 2.8V Digital	
SLEEPCLK	32.768kHz Sleep Clock	CCONT to MAD4	0 to 2.8V Digital	Oscillator still running when phone is powered down.
RF Interface Control Signals				
CAFE_TX_GATE	Transmitter Gating Signal	MAD4 to RF	0 to 2.8V Digital	
TIF_EN	TIF chip enable	MAD4 to RF	0 to 2.8V Digital	
SYN_ACQ&SYN_P WR_DN		MAD4 to RF	0 to 2.8V Digital	
SYN_LK1		MAD4 to RF	0 to 2.8V Digital	
RIF_EN		MAD4 to RF	0 to 2.8V Digital	
TX_LIM	Indicates TX Power Greater than TXI_REF	RF to MAD4		
SYN_CLK	R/F I/F Serial Clock	MAD4 to RF	0 to 2.8V Digital	
SYN_DAT	R/F I/F Serial Data	MAD4 to RF	0 to 2.8V Digital	
SYN_LE1	R/F I/F Serial Latch Enable #1	MAD4 to RF	0 to 2.8V Digital	
CEL_MODE	R/F I/F Serial Latch Enable #2	MAD4 to RF	0 to 2.8V Digital	
BAND_SEL	RF Frequency Band Select (PCS or Cellular)	MAD4 to RF	0 to 2.8V Digital	
MODE_SEL	RF Mode Select (CDMA or AMPS)	MAD4 to RF	0 to 2.8V Digital	

SIGNAL NAME	DESCRIPTION	From/To	Signal Characteristics	Notes
AFC	AFC PDM	MAD4 to RF	0 to 2.8V continuously variable	
RX_IF_AGC	Receive IF AGC PDM	MAD4 to RF	0 to 2.8V continuously variable	
TX_IF_AGC	Transmit IF AGC PDM	MAD4 to RF	0 to 2.8V continuously variable	
TX_RF_AGC	Transmit RF AGC PDM	MAD4 to RF	0 to 2.8V continuously variable	
TX_VCO_CAL	PENTA Regulator control (P5)	MAD4 to RF	0 to 2.8V	Not used as a PDM
TX_LIM_ADJ	General Purpose PDM2	MAD4 to RF	0 to 2.8V continuously variable	
FILT_SEL	General Purpose PDM3	MAD4 to RF	0 to 2.8V Digital	Not used as a PDM
BOOST	General Purpose PDM4	MAD4 to RF	0 to 2.8V continuously variable	
RX_GS	RF Receive Gain Switch function	MAD4 to RF	0 to 2.8V Digital	
RF_TX_GATE_P	Transmitter Gating Signal (PCS Mode)	MAD4 to RF	0 to 2.8V Digital	
RF_TX_GATE_C	Transmitter Gating Signal (Cellular Mode)	MAD4 to RF	0 to 2.8V Digital	
CLK_EN	VCTCXO Enable (to CCont "SLEEPX" input)	MAD4 to CCONT	0 to 2.8V Digital	Signal to CCONT which controls regulators to RF.
VLIM	Used to select the max battery voltage for the charging circuit in CHAPS (VLIM1 or VLIM2).	MAD4 to CHAPS	0 to 2.8V Digital	
Peripherals, Accessory Interface, and A/Ds				
BUZZER	Buzzer PWM Output	MAD4 to UI connector	0 to 2.8V Digital	
VIBRA	PWM output for vibra motor	MAD4 to on board VIBRA circuit, and to battery connector via BTEMP line	0 to 2.8V Digital	
HOOKINT	Hook Interrupt	CAFE to MAD4	0 to 2.8V Digital	
EAD_HEADINT	Headset Interrupt (CCONT performs A/D on this signal).	CAFE to MAD4 and CCONT		
tp4	DBUS data line test point	MAD4	0 to 2.8V Digital	
RS232_PWR	Control for switching power onto SGND while using a data cable accessory.	N306 (regulator) to System connector	0 to 2.8V Digital	Controlled by MAD4
BSI	Intelligent Battery Interface. A/D input to CCONT.	Battery connector to CCONT	DC voltage level that varies with different battery types.	Voltage divider A/D input to CCONT

SIGNAL NAME	DESCRIPTION	From/To	Signal Characteristics	Notes
BTEMP	A/D input to CCONT. Used for battery temperature detection and battery VIBRA control.	Battery Connector to CCONT	DC voltage level which changes with battery temperature.	Thermistor voltage divider A/D input to CCONT
PA_TEMP	A/D input to CCONT. Used for RF power amp temperature detection.	RF to CCONT	DC voltage level which changes with PA temperature.	Thermistor voltage divider A/D input to CCONT
RSSI	A/D input to CCONT. Receive signal strength indicator for AMPS mode.	RF to CCONT	DC voltage level which changes with received signal strength.	
V_IN	Power in from charger	System connector to CHAPS	ACP-9 DC ACP-7 Rectified AC	Voltage will change with charge control PWM.
L_GND	Ground reference for charger (Separated from GND through an inductor).	System connector to GND via inductor	0V	
Regulator Control Signals				
VREGP1	Controls voltage regulator P1 (PENTA).	MAD4 to CCONT	0 to 2.8V Digital	
VREGP2	Used to control voltage regulator P2 (PENTA). This signal is also the MSB (bit-21) of the Memory Address Bus but is not used as an address bit.	MAD4 to CCONT	0 to 2.8V Digital	
VREGP3	Controls voltage regulator P3 (PENTA).	MAD4 to CCONT	0 to 2.8V Digital	
VREGP4	Controls voltage regulator P4 (PENTA).	MAD4 to CCONT	0 to 2.8V Digital	
CCONT_INT	CCONT interrupt to MAD4	CCONT to MAD4	0 to 2.8V Digital	
User Interface Board Peripherals				
FLIP	Flip interrupt (detects status of hinge) on variants with flip feature.	UI connector to MAD4	0 to 2.8V Digital	
BACKLIGHT	Controls illumination on UI board.	MAD4 to UI connector	0 to 2.8V Digital	
CALL_LED	Controls the call LED on UI board.	MAD4 to UI connector	0 to 2.8V Digital	
LCD_RESETX	Resets the LCD on the UI board.	MAD4 to UI connector	0 to 2.8V Digital	
COL(4:0)	Keyboard Columns on UI board.	MAD4 to UI connector	0 to 2.8V Digital	
UIF(5:0)	Keyboard Rows and LCD I/F	MAD4 to UI connector	0 to 2.8V Digital	

SIGNAL NAME	DESCRIPTION	From/To	Signal Characteristics	Notes
PWRONX	Power button signal	UI connector to MAD4	0 to 2.8V Digital	
Resets				
PURX	Power Up Reset	CCONT to MAD4	0 to 2.8V Digital	
RESETX	System Reset	MAD4 to CAFE	0 to 2.8V Digital	
CAFE RF/IF				
IQSEL	IQ Select control line for selecting I or Q data	MAD4 to CAFE	0 to 2.8V Digital	
RXIQ(3:0)	CDMA Receive I and Q data	RF to CAFE	Differential I and Differential Q	
TXIQ(3:0)	CDMA Transmit I and Q data	CAFE to RF	Differential I and Differential Q	
LIM_P	non-inverting AMPS receive modulated signal	RF to CAFE	analog	
LIM_N	Inverting AMPS receive modulated signal	RF to CAFE	analog	
CLK19M2RF	19.2MHz sinusiod from RF	RF to CAFE	sinusoid	
AMPSMOD	AMPS audio signal (after DSP and D/A) to be transmitted.	CAFE to RF	analog (voice)	
Test & Emulation				
JTAG1_TRST	JTAG Reset	MAD4	0 to 2.8V Digital	
JTAG2_TDI	JTAG Scan Input	MAD4	0 to 2.8V Digital	
JTAG3_TDO	JTAG Scan Output	MAD4	0 to 2.8V Digital	
JTAG4_TCK	JTAG Clock & ATPG Scan Clock	MAD4	0 to 2.8V Digital	
JTAG5_PD	JTAG Mode Select & ATPG Scan Enable	MAD4	0 to 2.8V Digital	
JTAG0	DSP/MCU Emulation (NOT USED)	MAD4	0 to 2.8V Digital	
JTAG6	DSP/MCU Emulation (NOT USED)	MAD4	0 to 2.8V Digital	
	DSP External Flag (NOTE: This pin has a dual function as General Purpose I/O "POGPIO(6)". DSPXF is default function.)	MAD4	0 to 2.8V Digital	
CHRG_CTRL_A	DSP Serial Port Input Clock (for multipath analyzer)	MAD4	0 to 2.8V Digital	
TP5	DSP Serial Port Frame Sync(for multipath analyzer)	MAD4	0 to 2.8V Digital	
WDDIS	Watchdog Disable	Test Connector to CCONT	0 to 2.8V Digital	Used in factory while still in panel
CCONT Outputs				

SIGNAL NAME	DESCRIPTION	From/To	Signal Characteristics	Notes
VBB	LEAD power pins (DSP)	CCONT to MAD4 and memories as the UI connector	2.8V regulator	
VR1_SW	Power for microphone bias	CCONT to V201 (CAFE)	2.8V regulator	
VR1	Provides RF power	to RF	2.8V regulator	
VR2	Provides RF power	to RF	2.8V regulator	
VR3	Provides RF power	to RF	2.8V regulator	
VR4	Provides RF power	to RF	2.8V regulator	
VR5	Provides RF power	to RF	2.8V regulator	
VR6	Provides power to CAFE	to RF	2.8V regulator	
VR7	Provides RF power	to RF	2.8V regulator	
VR7A	provides RF power	to RF	2.8V regulator	regulator external to CCONT
VREF	Used by CAFE as an A/D voltage reference	to CAFE	1.244V reference	
VMAD	Provides power to the MAD4 core. Will be used only with the ROM3 version of MAD4.	CCONT to MAD4	1.8V regulator	Programmable to different voltages
+5V_POWER	Provides 5V power to RF	to RF	4.7 to 5.2V	Charge pump
3V_5V	Provides 3V to flash (Vpp) for programming	CCONT to FLASH	2.7 to 3.3V	used at 3V
CHRG_CTRL	Charge control PWM signal for accessories	System connector to CHAPS. Can also be driven by CCONT	0 to 2.8V Digital	
Audio Signals				
EARN	Inverting part of the audio differential signal to the earpiece.	CAFE to UI connector	1.8Vp-p max	combined differential output from earn and earp is 3.6Vp-p max
EARP	Non-inverting part of the audio differential signal to the earpiece.	CAFE to UI connector	1.8Vp-p max	combined differential output from earn and earp is 3.6Vp-p max
XEAR	Single ended audio signal to bottom connector.	CAFE to System connector	1.8Vp-p max	single ended
MICP	Non-inverting part of the audio differential signal to the internal microphone.	System connector (mic) to CAFE	Can be used up to 1Vp-p	combined differential input from MICP and MICN is 2Vp-p max

SIGNAL NAME	DESCRIPTION	From/To	Signal Characteristics	Notes
MICN	Inverting part of the audio differential signal to the internal microphone.	System connector (mic) to CAFE	Can be used up to 1Vp-p	combined differential input from MICP and MICN is 2Vp-p max
XMIC	Single ended external audio input from the bottom connector.	System connector to	Can be used up to 1Vp-p	
SGND	Return path for accessory audio, and power for data cable.	System connector to CAFE and N306	nearly 0V. Has some AC components.	Capacitively coupled input to CAFE. Resistive pulldown

CAFE Submodule

CDMA RX

The MAD/CAFE RX Interface consists of a 12-bit data bus RXD(11:0) output from the CAFE ASIC to the MAD ASIC. In CDMA mode the data transfer rate is 9.8304MHz. The RX data is clocked out of the CAFE ASIC on the falling edge of the 9.8304MHz clock, and clocked into the MAD ASIC on the rising edge. For CDMA mode the 4-bit RXI data is supplied on bits RXD(5:2) and the 4-bit RXQ data is supplied on bits RXD(11:8). Bits (7), (6), (1) and (0) are not used in CDMA mode.

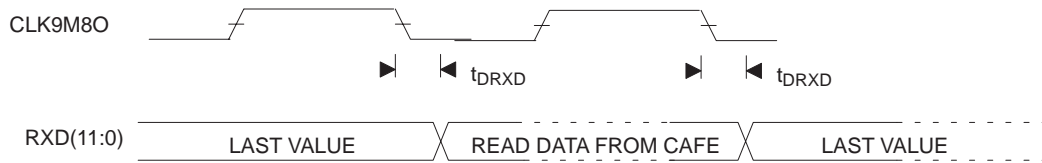

Digital Mode RX Data Bus Timing

CDMA TX

CDMA TX data is transferred from MAD4 to CAFE by using an 8-bit multiplexed parallel data bus TXD(7:0). The data is clocked out of MAD on the rising edge of the clock and clocked into the CAFE on the falling edge of the clock. The bus data rate is 9.8304 MHz.

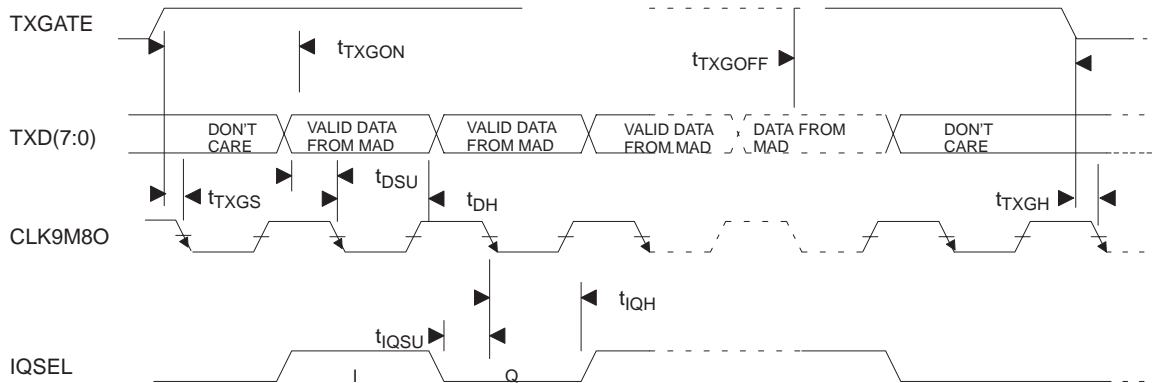

Digital Mode TX Data Bus Timing

AMPS RX

AMPS receive data from the RF section is differential, through pin 23 and 24 of the CAFE ASIC. RX data is transferred at 40 kHz through a 12-bit data bus RXD(11:0) output from the CAFE ASIC to the MAD4 ASIC. Wide band data (ADATA) is one bit asynchronous data running at 150 kHz.

Data conversion and the bus interface is synchronous. Data is clocked out of CAFE on the falling edge of the clock and clocked into the MAD4 on the rising edge of the clock.

AMPS TX

The TX data in AMPS mode is transferred at 120 kHz using an 8-bit multiplexed parallel data bus TXD(7:0). The AMPS transmit channel uses the Q channel. TX data is clocked out of MAD4 on the rising edge and clocked into the CAFE on the falling edge.

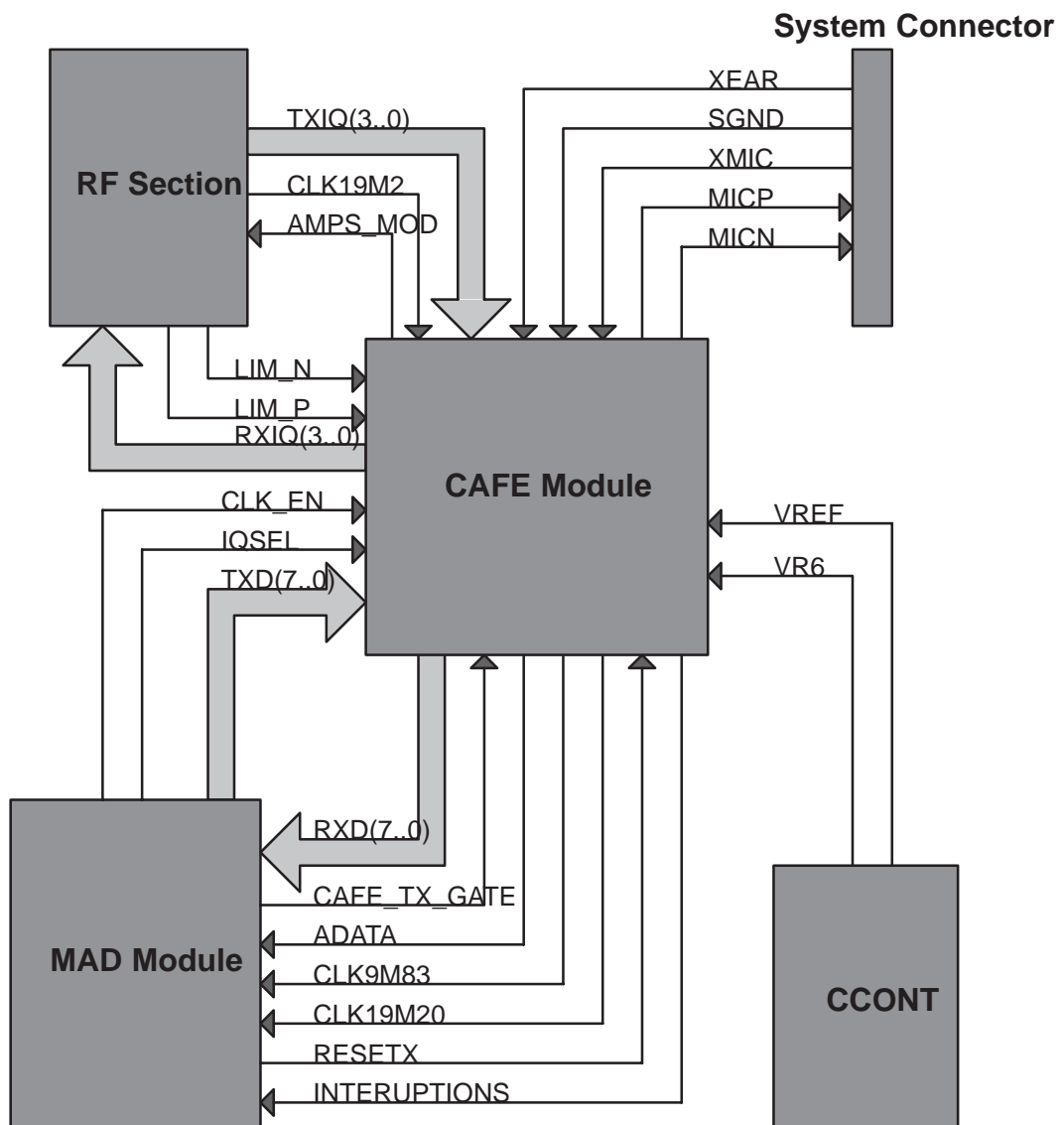

CAFE and Peripherals Block Diagram

Audio CODEC

The audio CODEC has the following functional blocks:

- 8 kHz interface for speech codec
- Microphone amplifiers and mux for 3 differential microphone inputs
- Variable gain amplifier for TX audio
- Variable gain amplifier for sidetone audio
- 13 bit Analog to Digital converter and lowpass filter
- 13 bit Digital to Analog converter and lowpass filter
- Variable gain amplifier for RX audio
- Speaker amplifiers for 3 speakers

Transmit

The microphone signal, MICP and MICN, is sent to CAFE differentially through pin 66 and pin 69. The maximum input signal level at either input is 1.0 V, which gives a differential level of 2.0 V_{pp}. Audio data is transferred in 16 bit frames (2 LSBs are not used).

The audio signal from an external accessory (XMIC) drives pin 68. The ground reference for XMIC is SGND (pin 67), which is a virtual ground.

Receive

The audio receive path consists of a D/A converter, lowpass filter and output attenuator with three selectable outputs. Only one output can be active at a time. The biasing at the outputs can be independently controlled to be ON at all outputs to avoid switching transients.

The EAR output from pin 77 and pin 80 is intended to drive a phone ear-piece having typically 32 ohm resistance. The output is differential, having positive (EARP) and negative (EARN) output terminals.

The HF output is intended to drive external audio circuitry via XEAR. The output is single-ended, but also has another pin (HFCM) which drives signal ground for it.

Detection

The external microphone input is detected by the voltage divider between R205 and R219 (EAD_HEADINT, A/D to by CCONT). When XEAR is loaded, it can pull down R213 and generate an interrupt to MAD4 (HOOK-INT).

External Microphone Biasing

AUXOUT is used to generate biasing voltage for the external microphone, and will provide 1.5 V bias voltage to the external microphone. If AUX-OUT is not selected, the output will be in high impedance state.

R202, R220, C212, and V201 provide an alternative means of biasing the internal microphone.

EMC Strategy

The baseband EMC strategy is divided into electrical and mechanical items. As electrical guide lines, clocks and high speed signals should be routed in inner layers and away from the PCB edges. Clock signals distributed to other circuits should have series resistors incorporated to reduce rise times and reflections. Slew rate controlled buffers should be used on custom components wherever possible to reduce the EMC produced by the circuit. Separate power supplies for digital, analog and rf-blocks should be used as much as possible. Baseband and RF supply power rails should be isolated from each other by means of inductors in the power supply rail to prevent high frequency components produced on the baseband power supply rail to spread out over the RF power supply plane. This might be required to avoid interference from digital circuits to affect the performance of RF section.

All external connectors and connection must be filtered using RC or LC networks to prevent the high frequency components from entering connection cables that then will act as antennas. The amount of this type of EMC component is in straight relation to the amount of external connections. The type of network and amount of components to be used is determined by the AC and DC impedance characteristic of that particular signal. Low impedance signals requires LC network while medium impedance level signals, input signals at moderate band width can use RC networks.

The EMC protection should also prevent external or internal signals to cause interference to baseband and in particular to audio signals. Internal interference is generated by the transmitter CDMA frequency and the switch mode charging. The transmitter CDMA frequency interference is likely to cause noise to both microphone and earphone signals. The transmitter RF interference is likely to cause more problems in the microphone circuitry than in the earphone circuitry since the earpiece is a low impedance dynamic type.

As mechanical guide lines, the baseband and RF sections should be isolated from each other using EMC shielding, which suppresses radiated interferences. The transmitter CDMA frequency can also generate mechanical vibrations that can be picked up by the microphone if it is not properly isolated from the chassis using rubber or some other soft material. A spring connected microphone is used to prevent microphone interference problems. Connection wires to internal microphone and earphone should be as short as possible to reduce the interference caused by internal signals.

ESD protection has to be implemented on each external connection that is accessible during normal operation of the phone.

RF Module

Transmitter

The following sections describe the 800, 1900MHz transmitters working from the Duplexers back to the Base Band signals.

Antenna

A dual band antenna was developed for the phone. The Antenna has two electrical contacts that must be made to the phone.

Diplexer

Since the product is Dual Band we have two Duplexers. A ceramic 1900 MHz duplexer and a SAW 800 MHz duplexer. Since only one antenna is used it is necessary to diplex the two duplexers together. This is done using a discrete network that is shown in the figure below. Part of this network is printed on the PCB.

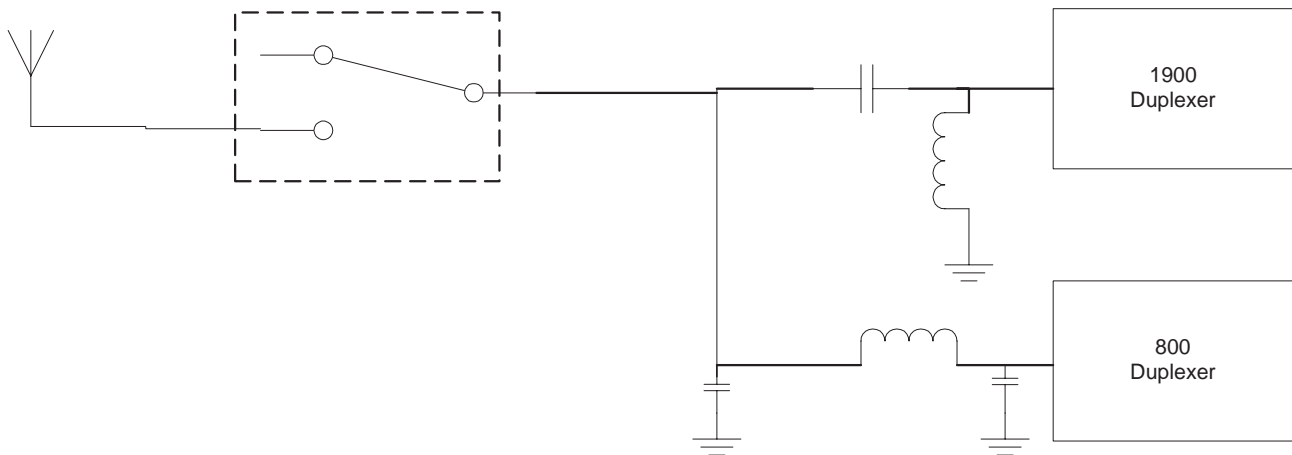

1900 MHz Transmitter

The following sections describe the 1900MHz transmitters working from the Duplexers back to the Base Band signals.

1900MHz Duplexer Scorpion

The 1900 MHz duplexer known, as “Scorpion” is a ceramic mono block device. The front of the duplexer is covered with a shield. It is **crucial that this shield is well soldered down to avoid rejection problems**. Solder joints along the mono block front (i.e. shield side) are also critical for rejection while solder joints at the rear of duplexer serve only as mechanical securing. Due to the problem of silver leaching the corners of the duplexer should NOT be soldered, only flat sections of the part should be soldered.

1900 MHz Isolator

RF Isolators are used the 1900MHz transmitter, its reference designators is Z605. It is in the industry standard 7 x 7 mm packages and an arrow on

the top of the package indicates the direction of power flow. It allows power to flow only from the PA to the Duplexer and not in the reverse direction. This means that the impedance that is presented to the PA remains the same regardless of channel. It also avoids the use of a directional coupler for power detection.

1900 MHz Power Amplifiers Snapper

The Power Amplifier is a GaAs HBT Device. The 1900MHz PA is referred to as SNAPPER, reference designator N606. The device is two stage and requires both external inter stage and external output matching, part of this matching is printed on the PCB. It is packaged in a standard SSOP16 plastic package with a heat sink slug underneath. The metal slug on the underside, which serves primarily as a heat sink, but also as an RF ground connection. A grid of vias are present under the slug to help conduct heat into the PCB and all layers have a maximum amount of copper under the PA's to assist with heat dissipation.

The PA is connected directly to Vbatt through an inductor. It is through this inductor that most of the current consumed by the PA flows. The PA is switched on and off by controlling its bias. Since a voltage of greater than 3.8v was required for the bias the 5 volt output from CCONT has been utilized. The signal for controlling the PA comes from MAD and are called TX_GATE_P. This line switches the +5 volts from CCONT via N60x to the VREF pin on SNAPPER. When the TX_GATE line is high (i.e. at 2.7 volts) the 5 volts is switched onto the bias and the PA is on, if there is no RF input to the PA then it will draw approximately 100 mA.

1900 MHz Transmitter Interstage Filtering

Due to the small separation between the Tx Band 1850 –1910MHz and the Rx band 1930 – 1900 MHz it is extremely difficult to filter the Tx noise from the Rx band to a level acceptable to the receiver. To achieve the rejection we required using SAW filter technology, it was necessary to split the band into two 30 MHz wide sections.

Splitting the band into two allowed us to get significantly more rejection, however we now have the problem of switching between the two bands. Fortunately it was possible for the vendor to place both these SAW filters in a single 4 x 4mm package reference designator Z602. In order to use this filter, the Tx signal obviously needs to be switched to the correct filter section. This is achieved on the output (before the PA) with a GaAs switch reference designator N609, and on the input by a switch integrated into the up-converter IC Apache reference designator N601. Both switches are controlled by a signal from MAD4 called FILT_SEL.

The GaAs switch N609 requires a transistor to control it V614 since it requires both high and low signal simultaneously and only one control line is available from MAD4 to control the switch.

1900 MHz Transmitter Up-converter Apache

Apache reference designator N601 is the 1900MHz Up converter. This IC is contained in an SSOP24 plastic package and is responsible for mixing

the transmit IF signal up to the required RF and amplifying in to a level sufficient to drive the PA to produce the required output power. Apache also incorporates a Voltage Variable Attenuator (VVA), this attenuator provides nearly 20dB of RF power control by varying the TX_RF_AGC line. The VVA is included since it is very difficult to provide all of the huge dynamic range required by CDMA at the intermediate frequency.

The Tx up-converter incorporates an IF amplifier (IFA) a mixer with LO buffer followed by RF amplifier (RFA), Voltage Variable Attenuator (VVA) followed by a driver. Finally the driver output is switched to two outputs for each of the split band filter inputs. A SAW filter reference designator Z601 prior to the VVA input filters the output of the RFA.

The Apache IC runs on two power supplies for two reasons, one the CCONT was not able to source enough current for the whole IC and secondly the extra 0.3 volts gained by using Vbatt for the Driver stage allows a big improvement in both output power and ACPR. The IFA and the LO buffer are powered by VR4 from CCONT. The RFA and driver supplies come from Vbatt switched by a FET reference designator V606. The control for switching the power to the driver is TX_GATE_P i.e. the same line used to control the PA. The Driver stages are therefore “punctured” in exactly the same way, as the PA’s to save current.

A block diagram of the Apache IC is shown below:

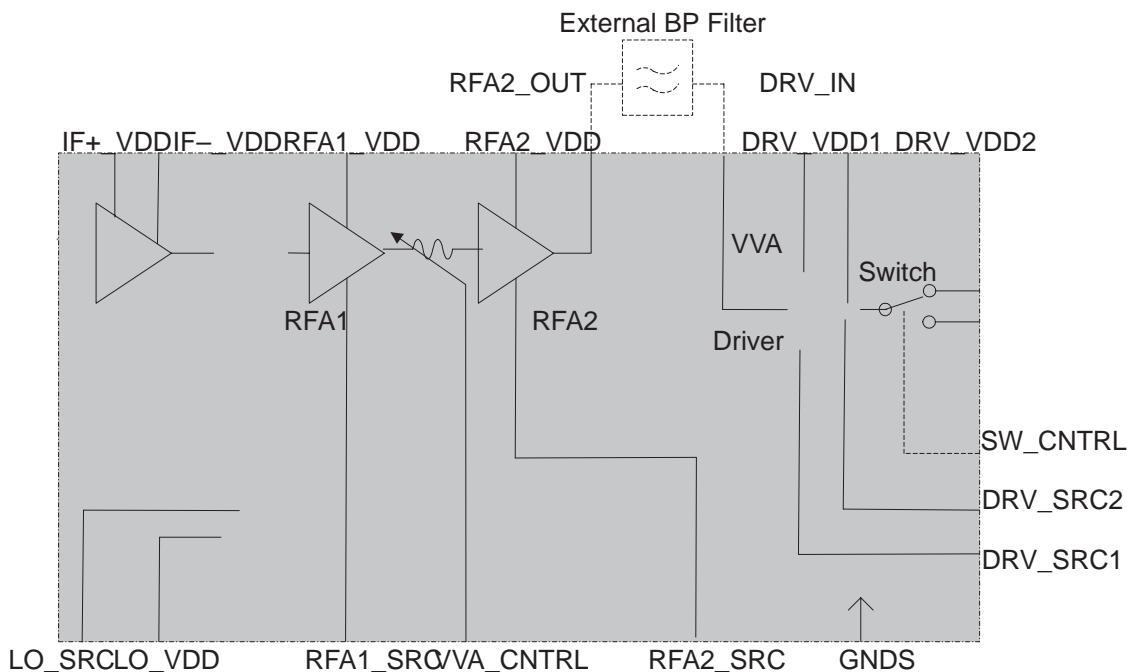

800 MHz Transmitter

The following sections describe the 800MHz transmitters working from the Duplexers back to the Base Band signals.

800 MHz SAW Duplexer

The 800 MHz duplexer used is of SAW technology. Proper soldering of all pins is necessary for correct rejection performance.

800 MHz Isolator

RF Isolators are used the 800MHz transmitter, its reference designators is Z60x. It is in the industry standard 7 x 7 mm packages and an arrow on the top of the package indicates the direction of power flow. It allows power to flow only from the PA to the Duplexer and not in the reverse direction. This means that the impedance that is presented to the PA remains the same regardless of channel. It also avoids the use of a directional coupler for power detection.

800 MHz Power Amplifiers Shark

The Power Amplifier PA is a GaAs HBT Device. The PA is referred to as SHARK reference designator N605. The device is two stage and requires both external inter stage and external output matching, part of this matching is printed on the PCB. It is packaged in a standard SSOP16 plastic package with a heat sink slug underneath. The metal slug on the underside, which serves primarily as a heat sink, but also as an RF ground connection. A grid of vias are present under the slug to help conduct heat into the PCB and all layers have a maximum amount of copper under the PA's to assist with heat dissipation.

Shark 800MHz PA has been designed to work in both Digital (CDMA mode) and Analog (AMPS Mode). The PA is connected directly to Vbatt through an inductor. It is through this inductor that most of the current consumed by the PA flows. The PA is switched on and off by controlling its bias. Since a voltage of greater than 3.8v was required for the bias the 5 volt output from CCONT has been utilized. The signal for controlling the PA come from MAD4 and is called TX_GATE_C for Snapper 1900MHz. This line switches the +5 volts from CCONT via N60x to the appropriate VREF pin on SHARK. When the TX_GATE line is high (i.e. at 2.7 volts) the 5 volts is switched onto the bias and the PA is on, if there is no RF input to the PA then it will draw approximately 100 mA.

800 MHz Transmitter Up-converter Odyssey

Odyssey reference designator N604 is the 800 MHz Up converter. This IC is contained in an SSOP28 plastic package and is responsible for mixing the transmit IF signal up to the required RF and amplifying in to a level sufficient to drive the PA to produce the required output power.

Odyssey also incorporates a Voltage Variable Attenuator (VVA), this attenuator provides nearly 20dB of RF power control by varying the TX_RF_AGC line. The VVA is included since it is very difficult to provide all of the huge dynamic range required by CDMA at the intermediate frequency.

The Tx up-converter incorporates an IF amplifier (IFA) a mixer with LO buffer followed by RF amplifier (RFA), Voltage Variable Attenuator (VVA) followed by a driver. Finally the driver output is switched to two outputs for each of the split band filter inputs. A SAW filter reference designator Z606 prior to the VVA input filters the output of the RFA.

The Odyssey IC runs on two power supplies for two reasons, one the CCONT was not able to source enough current for the whole IC and secondly the extra 0.3 volts gained by using Vbatt for the Driver stage allows a big improvement in both output power and ACPR. The IFA and the LO buffer are powered by VR5 from CCONT. The RFA and driver supplies come from Vbatt switched by a FET reference designator V602. The control for switching the power to the driver is TX_GATE_C i.e. the same line used to control the PA. The Driver stages are therefore “punctured” in exactly the same way as the PA’s to save current.

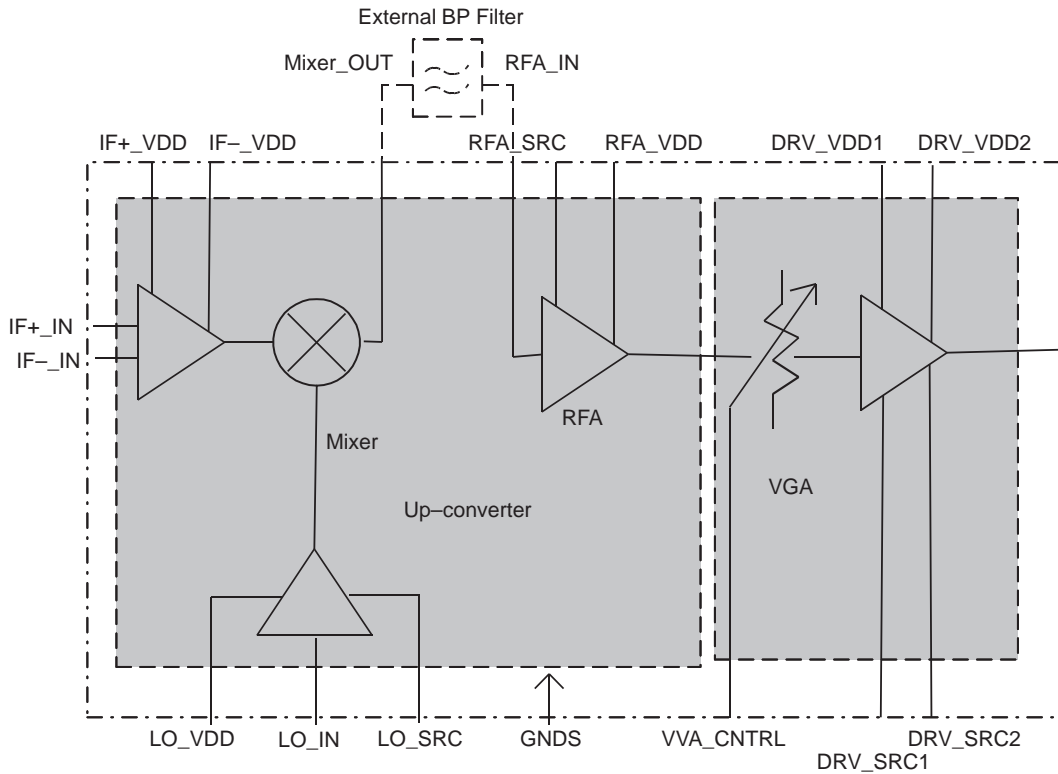

800 MHz and 1900 MHz Transmitter Intermediate Frequency (TIF)

The TIF IC generates the Intermediate Frequency (IF) for both the 800MHz and 1900MHz transmitters. This IC reference designator N604 incorporates the IQ modulator for CDMA mode, 85dB of dynamic range control and a switch for the two transmitters. Also included in the TIF IC is most of the circuitry required for the power detection for both CDMA over power detection and AMPS mode closed loop power control.

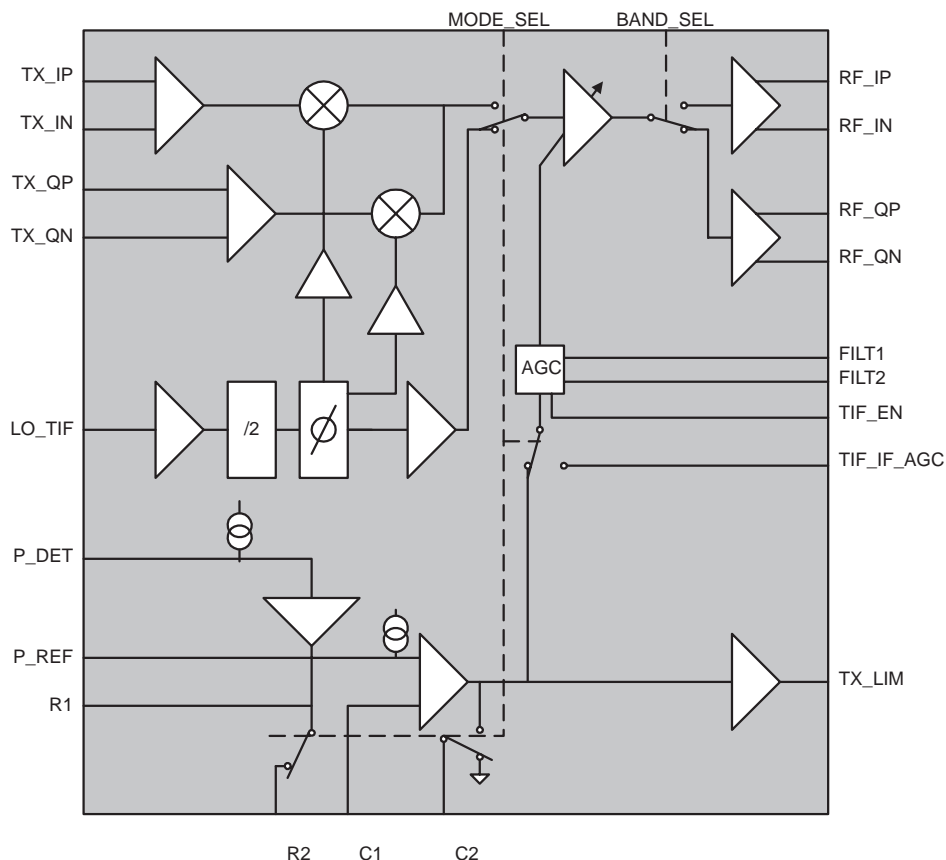

1900 MHz Receiver

The following sections describe the 1900MHz receiver working from the Duplexers to the Base Band signals.

1900 MHz LNA and Interstage Filter

The receiver port of the Duplexer is connected to a discrete Low Noise Amplifier (LNA). The discrete LNA consists of a Bipolar transistor reference designator V705 with active bias transistors V704. The external LNA is supplied by VR2 from CCONT. The LNA consumes 22mA of current.

The discrete LNA is followed by an inter stage filter reference designator Z707. The primary objective of this filter is to attenuate the transmitter signal band 1850 to 1910MHz which is not attenuated sufficiently by the Duplexer and to pass the receive band 1930 to 1990MHz with typically 3dB of attenuation.

1900 MHz Down Converter IC STEALTH

Stealth is the GaAs down converter IC that is used for 1900 MHz CDMA reception. The IC reference designator is N701 and it is packaged in a standard SSOP24 plastic package. The first Inter stage filter reference designator Z707 (mentioned above) is connected to the Stealth LNA input which has 17dB of Gain and NF of 2.1dB. The LNA output comes off chip

to the second inter stage filter and also a 7dB attenuator. The output of the attenuator is then connected back to stealth where the signal passes through an RF Amplifier (RFA) with 12dB of Gain. The signal is then mixed down to the IF frequency of 128.1MHz. The Mixer is a passive floating FET design, the LO for this is buffered inside Stealth. The mixer output is amplified by an IF amplifier (IFA) with 12dB of gain. The Stealth IC has the ability to lower the gain by 22dB by bypassing the LNA. It also has the ability to increase the LNA IP3 using the BOOST control which increases the LNA current.

Stealth is supplied by VR2 from CCONT and consumes 39mA in High Gain Mode (normal mode). If used in the other modes it would consume 30mA in Low Gain and 60mA in Boost Mode.

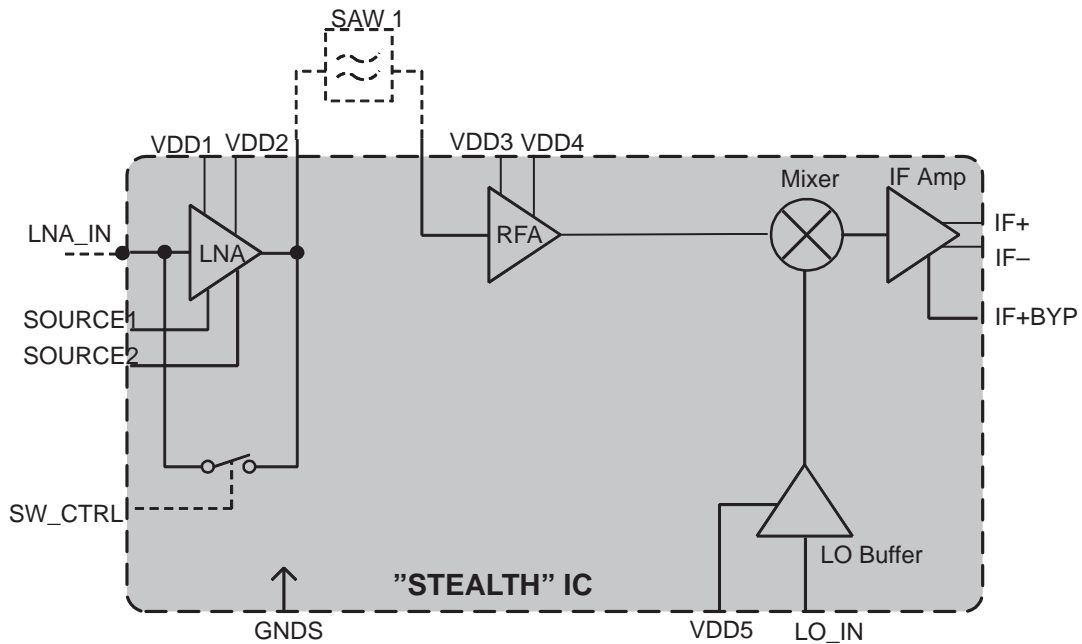

800 MHz and 1900 MHz CDMA IF filter

Both the 800 MHz CDMA path and the 1900 MHz CDMA Path use the CDMA IF filter reference designator Z704.

The 1900 MHz and 800 MHz down converters share the 128.1MHz IF SAW filter and this operates as follows.

When receiving a 1900 MHz CDMA signal the Stealth down converter IC is power up with VR2 and the 800MHz down converter IC Voyager powered from P4 is turned off. The IFA outputs from 800MHz down converter IC Voyager (which is connected to the CDMA IF SAW filter) become high impedance and do not interfere with the 1900 MHz received signal.

When receiving a 800 MHz CDMA signal the 800MHz down converter IC Voyager is switched on and the 1900 MHz down converter is switch off.

800 MHz Receiver

The following sections describe the 800MHz receiver working from the Duplexers to the Base Band signals.

800 MHz Down Converter IC VOYAGER

Voyager is the GaAs down converter IC used for the 800 MHz Band, it has been designed for both AMPS and CDMA reception. The IC reference designator is N703 and it is packaged in a standard SSOP28 plastic package. The Rx port of the 800 MHz Duplexer is connected to the LNA input of the Voyager Down converter IC. The LNA has 17dB of Gain and a NF of 2.2dB. The LNA output is brought off chip for the 800MHz Inter stage filter reference designator Z705. The filter output is connected to the Voyager RFA input and the signal is then mixed down to IF. Up to this point everything in Voyager is used for both CDMA and AMPS reception. The mixer output is connected to two IF Amplifiers one for CDMA and one for AMPS. The CDMA IFA has a gain of 15dB and its output is connected directly to the CDMA IF SAW filter. When the Voyager IC is switched off the impedance presented to the CDMA IF SAW filter is very high. The AMPS IFA is connected to the 128.55 MHz AMPS IF SAW filter.

800 MHz AMPS IF Filter

The AMPS IF filter reference designator Z702 is used for 800 MHz AMPS only.

The Intermediate frequency of the AMPS filter is 450KHz higher than that of the CDMA IF filter. The reason being that the AMPS path uses double conversion with second IF of 450KHz. Offsetting the first IF by 450KHz from the CDMA path allows the same second LO (of 128.1MHz) to be used for both CDMA and AMPS thereby simplifying the Synthesizer design.

Receiver Intermediate Frequency (RIF)

The RIF IC incorporates the following functions CDMA AGC, IQ Demodulator and AMPS second conversion and Limiter. These functions are explained in the following sections. The RIF IC is powered from the VR7 regulator from CCONT and consumes approximately 24 mA of current. The RIF IC reference designator is N702 and it is packaged in a standard TQFP32 plastic package.

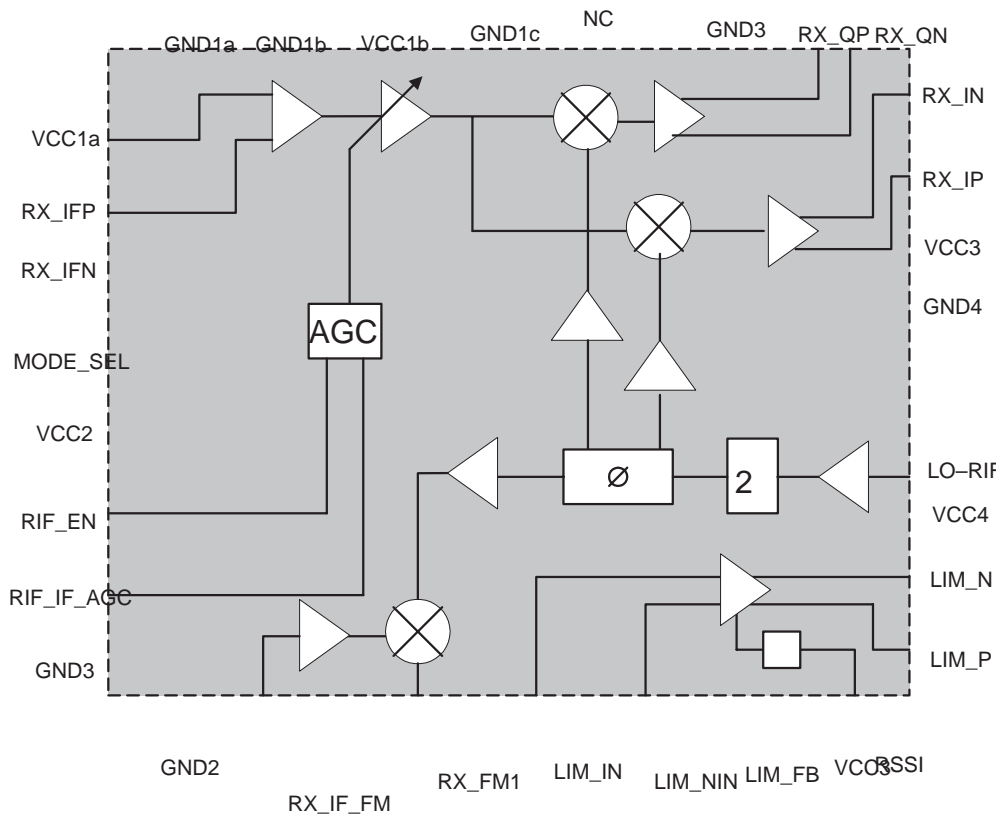

CDMA AGC

The RIF IC contains a wide dynamic range AGC circuit for CDMA. The AGC provides +45 to -45dB of Gain controlled by the PDM Line RX_IF_AGC.

IQ Demodulator

The IQ demodulator mixes the 128.1MHz IF signal down to DC with two mixers one at quadrature to the other. The LO is at 256.2MHz and is divided by two in the demodulator.

AMPS Second Down conversion

The AMPS path is designed with a second IF of 450KHz. The RIF IC amplifies the 128.55MHz IF signal and then mixes it down to 450KHz with the 256.2MHz LO (divided by 2 to 128.1MHz).

AMPS Limiter

The 450KHz output is then taken off chip to the 450KHz Ceramic 2nd IF filter after which the signal returns to RIF where it is passed through a limiting amplifier. The Limiter output is then band pass filtered to generated a wave form than can be interpreted by the DEMO block in CAFE.

Synthesizers

The frequency plan requires the following Local Oscillator (LO) frequencies to be synthesized. The power supplies to these synthesizers have been designed to minimize power consumption.

UHF LOs 1 GHz and 2 GHz

The 800 MHz band and 1900 MHz band each require their own UHF LO to select the required channel. Since only one is required at a time the PLL IC Reference designator N501 is used for both LO and only the correct Voltage Controlled Oscillator (VCO) switch on. The loop filter for the two bands is also shared by the two bands. The PLL IC N501 is powered by VR3 from CCONT and is switched on in both Receive and Transmit modes. The R and N counters are programmed by the lines SYN_DAT, SYN_CLK and SYN_LE1 from MAD to achieve the correct output frequency. The PLL IC N501 also incorporates a VHF PLL which is used for the Transmitter LO.

The 1 GHz VCO reference designator G503 is powered by P1 from PENTA and the 2GHz reference designator G502 is powered by P3 from PENTA.

Receiver VHF LO

The receiver requires a 256.2 MHz LO in CDMA 1900 MHz, CDMA 800 MHz and AMPS modes. A mask programmed PLL IC is used which has fixed N counters to always produce the correct frequency with no programming required. The Receiver VHF VCO is a discrete design based around a bipolar transistor reference designator V506. The Receiver VHF LO is fed to the RIF IC.

Transmitter VHF LO

The transmitter requires three different LO frequencies depending on the Tx mode. The LO is not required in receive mode and is therefore not powered up for receive only slots.

The transmitter VHF VCO is a discrete design based around a bipolar transistor reference designator V508. To cover the wide frequency range required above the VCO also uses the BAND_SEL control line from MAD to switch a capacitor in and out of the VCO. Finally in AMPS mode the Frequency Modulation is applied directly to the VCO through the AMPS_MOD line. The Dual PLL IC used for the UHF PLLs is also used for the VHF LO and is programmed using the same 3 control signals from MAD SYN_DAT, SYN_CLK and SYN_LE1. The transmitter VHF VCO is powered using a TOKO regulator reference designator N305 that is controlled by the VR7 supply from CCONT. This arrangement was required to give the VCO a very clean power supply.

RF – Base Band Connections

Signal Name	From/Control	To	Parameter	Min	Typ	Max	Unit	Function
VBAT	battery	Penta 2.8v reg. PA Odyssey & Apache	Voltage	3.1	3.6	5.3	v	Supply voltage for Penta regulators PA and PA Driver IC's
			Current			130 0	mA	
VR1	CCONT	VCTCXO and VCTCXO buffer	Voltage	2.7	2.8	2.8 5	v	Supply for VCTCXO and buffer
			Current			5.1	mA	
VR2	CCONT	Stealth 1900 Rx IC Discrete 1900 MHz LNA Rx IC Discrete	Voltage	2.7	2.8	2.8 5	v	Supply for Stealth 1900 Rx IC and discrete 1900 MHz LNA
			Current			68	mA	
VR3	CCONT	Dual PLL, Rx VHF PLL, Rx VHF VCO, RIF, CDMA IF Amp in Voyager and Stealth	Voltage	2.7	2.8	2.8 5	v	Supply for Dual PLL, Rx VHF PLL, Rx VHF VCO, RIF Rx IF IC, and the IF CDMA Amplifiers in Voyager and Stealth
			Current			55	mA	
VR4	CCONT	Apache 1900 Tx IC, discrete LO buffer	Voltage	2.7	2.8	2.8 5	v	Supply voltage for Apache 1900 MHz Tx IC and discrete 1900 MHz LO buffer
			Current			48	mA	
VR5	CCONT	Odyssey 800 Tx IC	Voltage	2.7	2.8	2.8 5	v	Supply voltage for Odyssey 800 MHz Tx IC
			Current			25	mA	
VR6	CCONT	CAFÉ	Voltage	2.7	2.8	2.8 5	v	Supply voltage for CAFÉ
			Current			43	mA	

VR7	CCONT	TIF, TOKO regulator control	Voltage	2.7	2.8	2.8 5	v	Supply voltage for TIF Transmitter Modulator and AGC IC. Control for TOKO regulator for Tx VHF VCO
			Current		24		mA	
P1	Penta	1 GHz VCO	Voltage	2.7	2.8	2.8 5	v	Supply for 800 MHz Band VHF VCO
			Current		16	20	mA	
P2	Penta	Voyager IF Amplifier	Voltage	2.7	2.8	2.8 5	v	Supply for Voyager IF Amplifier
			Current			12	mA	
P3	Penta	2 GHz VCO	Voltage	2.7	2.8	2.8 5	v	Supply for 1900 MHz Band VHF VCO
			Current		16	20	mA	
P4	Penta	Voyager 800 Rx IC	Voltage	2.7	2.8	2.8 5	v	Supply for 800 MHz Rx IC Voyager
			Current				mA	
P5	Penta	Discrete 1900 MHz LNA	Voltage	2.7	2.8	2.8 5	v	Supply for discrete 1900 MHz LNA
			Current		21	23	mA	
+5V POWER	CCONT	PA Bias circuitry 800 and 1900	Voltage					5v supply which is required to switch PA on
			Current		5	7	mA	
PA_TEMP	RF	CCONT	Voltage	0		1.5	v	RF temperature sensor 47K NTC to Ground
MODE_SEL	MAD	TIF, RIF	CDMA Mode		2.7		v	Digital or Analog Mode control
			AMPS Mode		0		v	
BAND_SEL	MAD	Tx VHF VCO, TIF	1900 Band		2.7		v	1900 or 800 MHz Band Control
			800 Band		0		v	
BOOST	MAD	Voyager, Stealth	Boost On		2.7		v	Boost control. Increases Rx IP3 but also increases current
			Boost Off		0		v	

RX_GS	MAD	Voyager, Stealth	High Gain		2.7		v	Low Gain mode by-passes the LNA in Voyager and Stealth, decreasing sens and current but increasing IP3
			Low Gain		0		v	
FILT_SEL	MAD	Apache1900 Tx, 1900 SAW control circuitry	1850-1880 (ch 0-599)		2.7		v	Control switch to switch RF path through correct section of SAW filter
			1880-1910 (ch 600-1199)		0		v	
CEL_MODE	MAD	Voyager	800 MHz CDMA		2.7		v	Control to switch CDMA IF Amp on 800 MHz CDMA
			PCS or AMPS		0		v	
RSSI	RIF	CCONT	Voltage	0.1		1.5	v	Voltage proportional to received signal strength in AMPS Mode
LIM_P	RIF	CAFÉ	Signal Voltage pk-pk		600		mV	Differential limited AMPS signal which is demodulated by DEMO in CAFÉ
LIM_N	RIF	CAFÉ	Signal Voltage pk-pk		600		mV	
RX_IP	RIF	CAFÉ	Signal Voltage pk-pk		2		v	Differential I channel CDMA signal, which is filtered and passed through a ADC in CAFÉ
RX_IN	RIF	CAFÉ	Signal Voltage pk-pk				v	
RX_IQ	RIF	CAFÉ	Signal Voltage pk-pk		2		v	Differential I channel CDMA signal, which is filtered and passed through a ADC in CAFÉ
RX_IQ	RIF	CAFÉ	Signal Voltage pk-pk		2		v	

RIF_EN	MAD	RIF	RIF On		2.7		v	Control line used to enable the RIF IC
			RIF Off		0		v	
RX_IF_AGC	MAD	RIF	PDM Voltage	0		2.7	v	IF Gain Control 8 bit PDM in MAD which is filtered to provide a DC level for RIF Gain Control
TIF_EN	MAD	TIF	TIF On		2.7		v	Control line used to enable the TIF IC
			TIF Off		0		v	
TX_LIM_ADJ	MAD	TIF	PDM Voltage	0		2.7	v	8 bit PDM in MAD is used to set one arm the comparator (the other (one detector) is in CDMA Mode.) It is used to set desired power in closed loop AMPS Mode
TX_LIM	TIF	MAD	Tx Higher than set on TX_LIM_ADJ			0	v	TX_LIM_ADJ and RF power detector comparator output read by MAD
			Tx Lower than set on TX_LIM_ADJ			2.7	v	
TX_RF_AGC	MAD	Apache and Odyssey	PDM Voltage Max Gain			0	v	8 bit PDM in MAD used to control the Voltage variable attenuator in Odyssey and Apache
			PDM Voltage Min Gain			2.7	v	
TX_IP	CAFÉ	TIF	Signal Voltage pk-pk		1		V	Differential I channel CDMA transmit signal
TX_IN	CAFÉ	TIF	Signal Voltage pk-pk		1		V	
TX_QP	CAFÉ	TIF	Signal Voltage pk-pk		1		V	Differential Q channel CDMA transmit signal
TX_QN	CAFÉ	TIF	Signal Voltage pk-pk		1		V	

TX_IF_ AGC	MAD	TIF	PDM Volt- age Max Gain		2.7		v	8 bit PDM in MAD used to control the IF Gain in TIF
			PDM Volt- age Min Gain		0		v	

This page intentionally left blank.